

Deformation Capacity of Semirigid Beam-to-column Connections in Steel Frames

Minoru Yamanari*

*Department of Architecture and Civil Engineering, Faculty of Engineering,
Kumamoto University,
2-39-1 Kurokami, Kumamoto, 860-8555, Japan*

ABSTRACT

This paper describes that beam-to-column connection deformations may have a significant effect on the behavior of semirigid steel frames subjected to earthquake excitations and the limits of their ability for keeping connected through the quake. Actual frames have areas that are called as panel zones at intersections of beams and columns, and beams are not connected perfectly rigid to columns, although primary frame analyses deal with those areas as points. In this study, not shear deformation in the panel zones but also local deformations of column walls at height of beam flanges were considered for dynamic response analyses of multi-storied steel frames. The local deformations are out of plane deformations of column walls caused by flange forces. A series of numerical computations on multi-storied semirigid steel frames incorporating various strength, initial stiffness and post yield stiffness of panel zones and beam-to-column connections are mentioned. If both panel zones and beam-to-column connections are weak and not so much rigid, the joints are weak links in which inelastic deformations are concentrated and the beams and columns will not develop their bending strength under lateral loading.

INTRODUCTION

In advanced seismic design of semirigid steel frames structures the question of adequate strength and stiffness of panel zones and beam-to-column connections should be discussed. It is a common knowledge that the damage which the building receives depends on the intensity of the distur-

* Associate Professor

bance. There is the fact that the damage level differs, even if the equal disturbance. Columns, beams and beam-to-column connections in the frame yield, when the structure receives the damage by the excessive disturbance, and they break. In other words, the energy absorption for the disturbance energy does in the time. This study focuses on beam-column connection rupture of the multi-storied semirigid steel frames in order to find the relation between joint rupture and collapse of the frame, and the performance in which the result got from the earthquake response analysis of the frame required beam-column connection was examined. The aim of this study is to get the required performance that does not generate and pays the joint rupture as the building received the earthquake disturbance.

JOINT RUPTURE AND FRAME COLLAPSE

A collapse of the overlay frame is considered in two kinds here. The former are layer collapse and tipping over collapse according to P - δ effect of the overlay frame, and the latter is the collapse in which local rupture like the member rupture is related to the whole frame. Though there is a case in which it comes to a layer collapse by generating the specific joint rupture in actual building, it is a rare phenomenon, and a collapse of the building generally does not occur. The layer collapses, because the limitless span frame has been made to be the analysis object in order to describe later, when the joint rupture was generated in the specific layer. Therefore, it shall also put this damage form in the category of a collapse of the frame in this study.

FRAME DESIGN

The frame for the analysis is shown in Fig. 1. The figure is part frame which took out 1 column center in point of inflection of the beam of right and left from the limitless span frame. Elements which constitute the frame are columns, beams, panel zones and rotation springs at the beam ends. The local deformation is not simple like column and beam which can model in the wire rod, and it is got by experimental result or formulation of the behavior from the finite element analysis result (Ref. 1), since the junction in the member subject edge is dependent in detail and resistant, and the application to the frame analysis has been made.

In the frame design, the ratio of rigidity and proof stress of the constructional element characterizes the frame performance. For example, the beam yield type frame is realized by lowering the yield resistance of beam member subject from the thing of pillar material. In this paper, the joint is similarly considered member, and strength and weakness of the joint are decided by evaluating thing with member subject in which it is opposite in other in respect of yield resistance of the

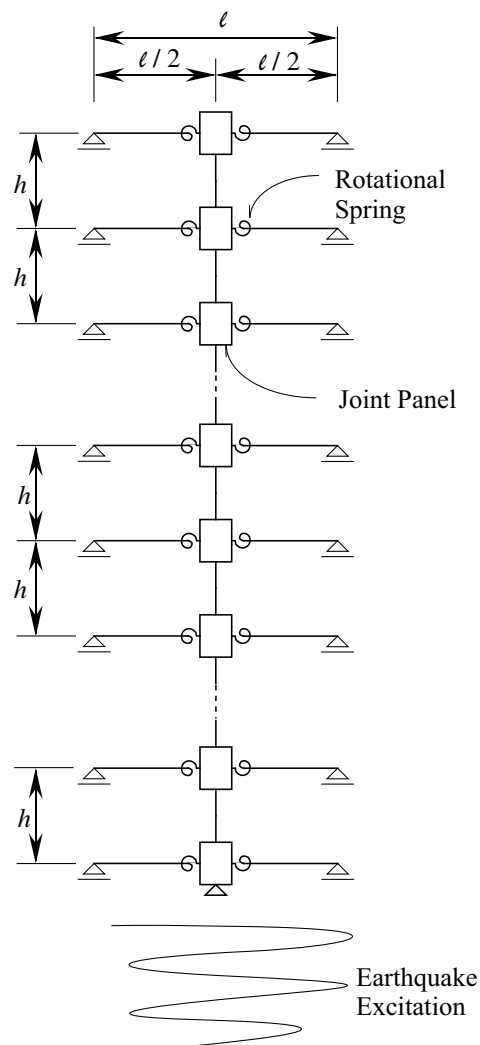

Fig 1. Model of semirigid frame under earthquake

joint. The yield resistance of panel zone and connection is defined using column and all plastic bending moment of beam member subject in following Eqs. 1 and 2. R_{P_P} and R_{P_L} shall be respectively called panel zone intensity ratio and connection intensity ratio.

$$R_{P_P} = \frac{M_{P_P}}{\min\left(\sum_{i=1}^2 M_{P_{B_i}}, \sum_{i=1}^2 M_{P_{C_i}}\right)} \quad (1)$$

$$R_{P_L} = \frac{M_{P_L}}{M_{P_B}} \quad (2)$$

in which, M_{P_B} , M_{P_C} , M_{P_P} and M_{P_L} are beam and column, yield resistance of panel zone and connection each.

Recently, the case of using the square steel pipe for the column is mainly observed in low-rise buildings. Here, wide flanges and Rectangular sections are respectively used for beams and columns, and outside diaphragms which represents for the type of semirigid beam-to-column connections are adopted. Rigidity K and yield resistance M_y with respect to panel zones and the semi-rigid beam-to-column connections are shown as equation (3) through equation (6).

$$K_P = G V_P \quad (3)$$

$$M_{P_Y} = \frac{1}{\sqrt{3}} V_P \sigma_Y \quad (4)$$

in which, V_P is the volume of the panel zone. G and σ_y are modulus for shearing and yield point of the panel.

$$K_L = 2.823 \left(\frac{B + H_D}{B}\right)^{4.603} \left(\frac{B + T_D}{B}\right)^{1.353} \left(\frac{B}{T_D}\right)^{2.371} \left(\frac{D_w}{B}\right)^{0.303} \frac{E I d^2}{(B/2)^3} \quad (5)$$

$$M_{L_y} = 3.85 \left(\frac{T_C}{B}\right)^{\frac{2}{3}} \left(\frac{T_D}{H_D + T_C}\right)^{\frac{2}{3}} \left(\frac{H_D + T_C}{B}\right) \frac{B^2 d}{2} \sigma_y \quad (6)$$

in which, B and T_C is outer diameter and thickness of column, H_D and T_D is height and thickness of stiffener respectively.

It was calculated so that the mean value of largest intercalation distortion angle of the frame may become 0.02 for column and cross section of the beam. In the case, the intensity of the input seismic wave was amplified at simulation speed response spectrum 150 *kine*. Frames scales are as follows.

- 1) It is made that it makes the floor height to be 350cm all, and it does the span length to be 700cm.
- 2) The frame is built in the second kind ground which is specified in Japanese Building Code.

Response analyses were executed in numerical integration by the Newmark- β ($\beta=1/4$) method. The interval of the numerical integration was made to be the 0.01 seconds. The damping constant of the frame is the Rayleigh type, and both first, secondary were 3.0 %.

RESTORING FORCE CHARACTERISTICS OF ELEMENTS

The much research has been made strength of stability model of the frame constructional element. The model with load-deformation relation of the bilinear type which Fig. 2 shows was adopted in order to put degree of simple as much as possible in the importance. The relation of the figure arranged for right and left shows the correspondence between repeated load-deformation relation which Kato and Akiyama proposed and load-deformation relation by the monotonic loading (Ref. [2]). Figure (a) and figure (b) are applied in column and joint, and figure (c) and figure (d) are applied to beam and connection.

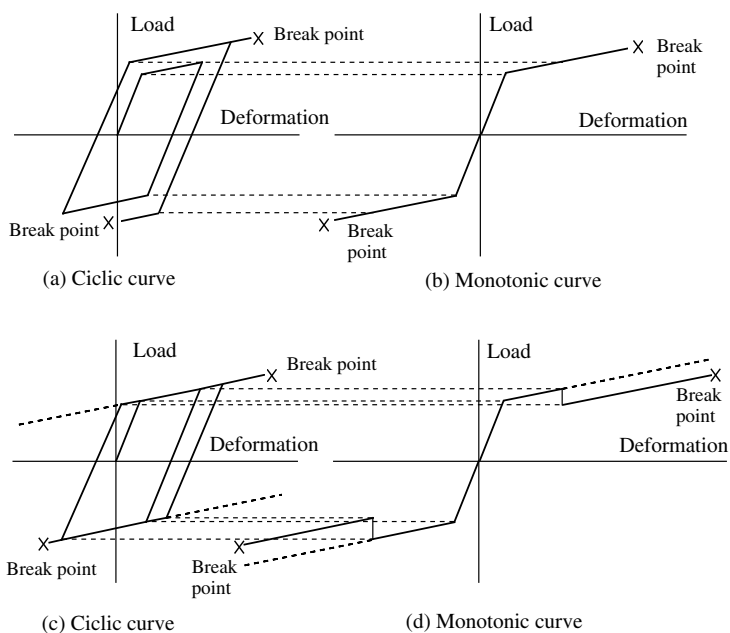

Fig. 2 Restoring Force Characteristics of Elements

RESPONSE SPECTRA

It tried to obtain response spectrum from the earthquake response calculation by the change of number of floors of the building, type of the earthquake and strength of connections. Fig. 3 shows the result. The solid lines in the figure represent speed pseudo spectra on velocity required from the acceleration of several earthquakes. Each plotted mark is the calculation result of each building. Each plotted mark is the calculation result of each building.

RUPTURE AND TIME

There is the high possibility in which the joint rupture occurs, when the joint is weaker than column or beam. Actually, Fig. 3 tells the aspect, and deformation volume and rupture time in breaking the joint become an object of the interest. The part of the result is shown in Table1. The limit of the deformation increases and rupture time shortens, if the strength of the joint is low.

RESULTS AND DISCUSSION

Fig. 4 plotted the accumulation plastic deformation magnification necessary for avoiding the rupture the juncture panel by the change of number of floors and input seismic wave of the frame, by the change of the intensity ratio of the panel. There is the change of the monotonous decrease regardless of number of floors and seismic wave of the frame in the figure. Necessary accumulation plastic deformation in case of the weakest intensity ratio as panel intensity ratio changes from 0.5 with 0.9's was about 20. In load testing of the panel zone, there is no rupture of panel itself like a common knowledge. In other words, the deformability of the panel got from the experiment is

by far exceeded than this calculation result.

In the meantime, Fig. 5 plotted the accumulation plastic deformation magnification necessary for avoiding the rupture the beam-to-column connection by the change of number of floors and input seismic wave of the frame, by the change of the intensity ratio of the connection. The change of the necessary accumulation plastic deformation magnification is less than other result for the result for Kobe, as it is shown in the figure.

CONCLUSIONS

Response studies were conducted to find design criteria for unbraced semirigid frames. Effects of joint strength and stiffness on response were derived from computational works. Summarized results are as follows:

- 1) The panel zone and the local deformation elements participate as energy absorbers in over-all frame.
- 2) Especially, the frames with weaker local deformation elements have better response than the frames designed conventionally.
- 3) Deformation capacity of semirigid connections in frames were deduced from numerical works using presented in this paper.

REFERENCES

- [1] Yamanari M. Ogawa K. and Kurobane Y., Evaluation of Rigidity of Connections with External Diaphragms Derived from FE Analysis, Journal of Structural Engineering, Vol. 38B, 1992, (in Japanese)
- [2] Kato B. and Akiyama H., Theoretical Prediction of the Load-Deflexion Relationship of Steel Members and Frames, Preliminary Publication of IABSE Symposium, Lisbon, 1973

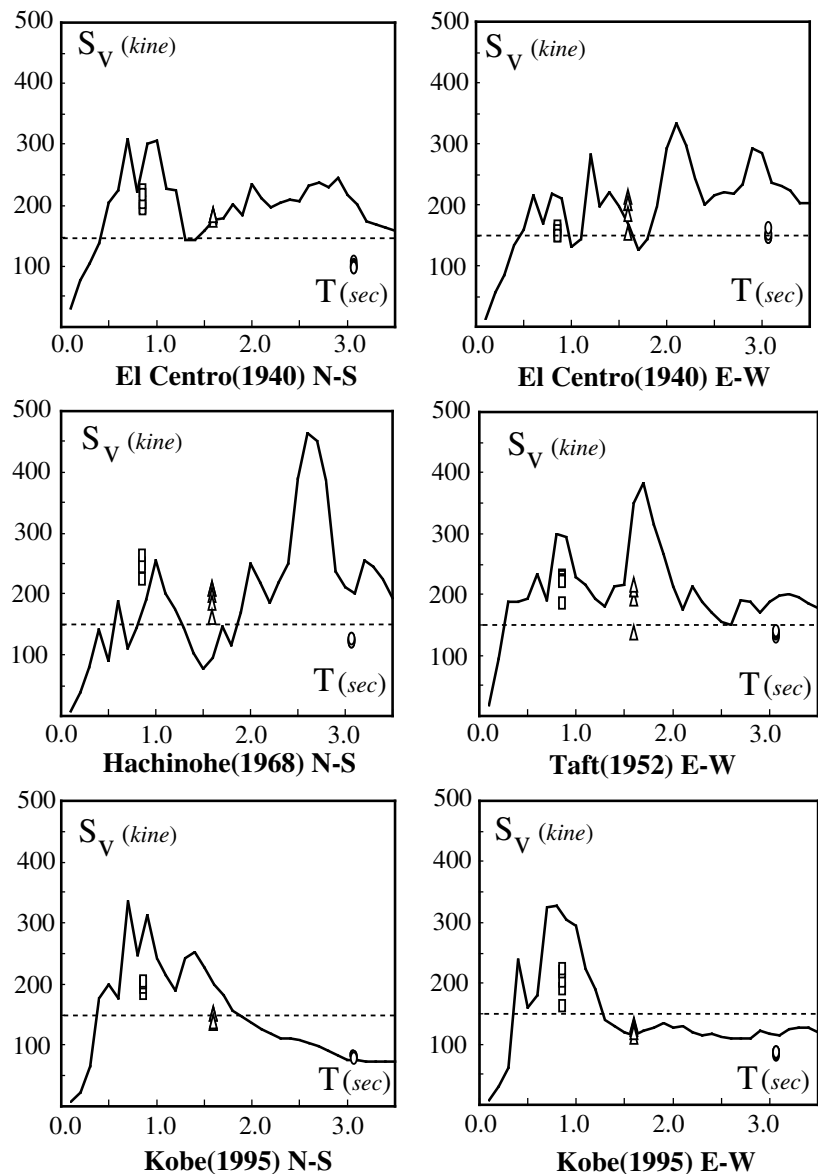

Fig.3 Response Spectra

Table 1 Deformation Capacity of Joint Panel and Breaking Time

El Centro (1940) NS					
R_{PP}	0.5	0.6	0.7	0.8	0.9
η_B	17.50	13.90	9.83	6.25	5.28
Time(sec)	12.04	4.44	4.43	12.44	4.40
Story	3	5	5	3	5
El Centro (1940) EW					
R_{PP}	0.5	0.6	0.7	0.8	0.9
η_B	12.60	10.81	8.36	5.18	2.84
Time(sec)	19.26	25.45	25.43	25.31	25.31
Story	5	5	5	3	3

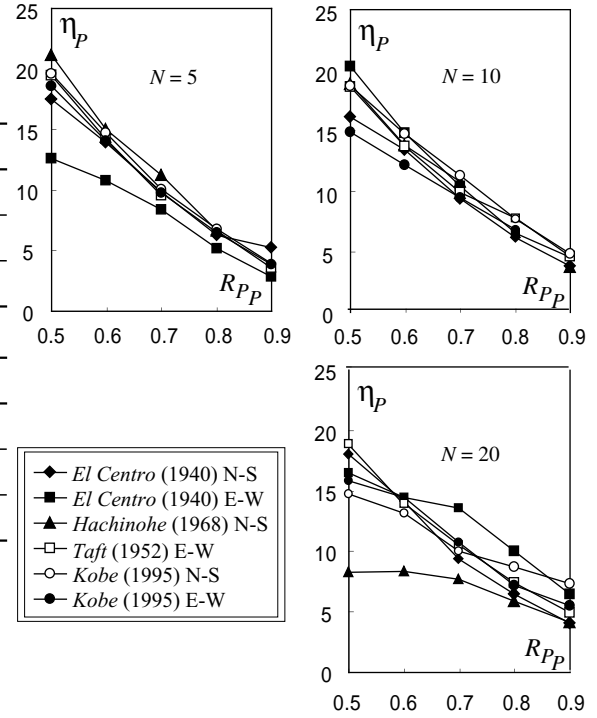

Fig. 4 Required Deformation Capacity of Joint Panel

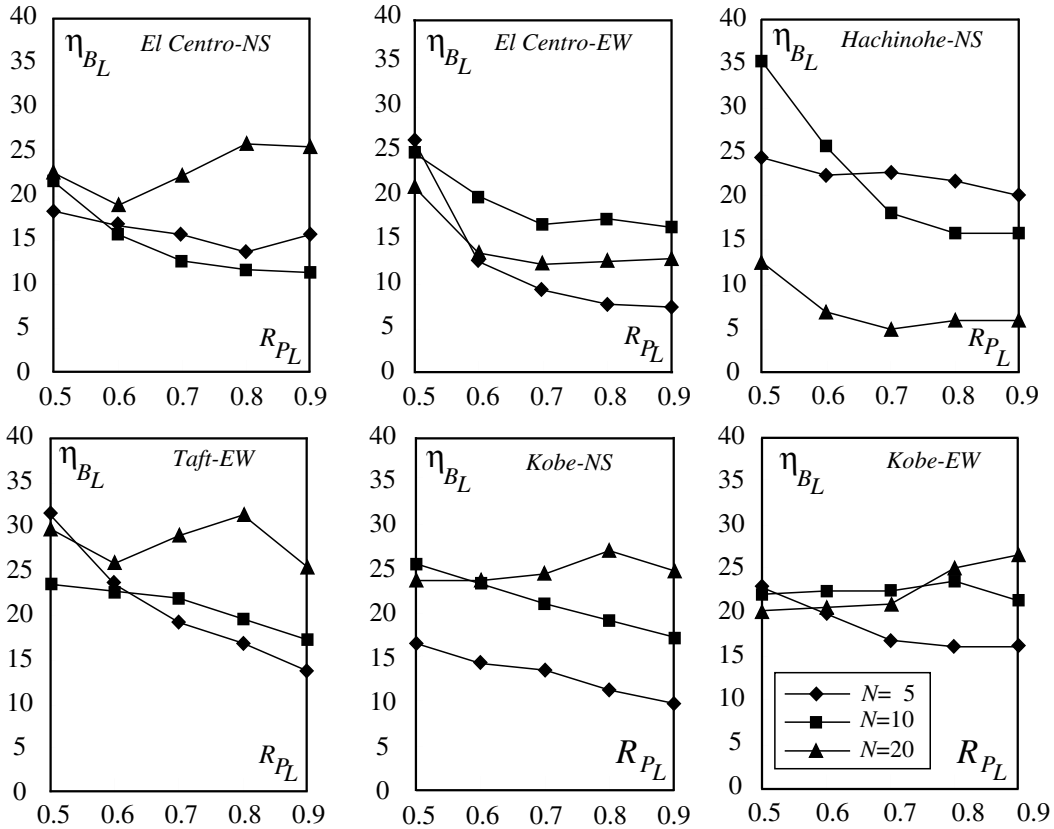

Fig. 5 Required Deformation Capacity of Beam-to-column Connection