

A Design Method of Model Error Compensator for Systems with Polytopic-type Uncertainty and Disturbances

Ryuichiro YOSHIDA *, Yuki TANIGAWA *, Hiroshi OKAJIMA *, and Nobutomo MATSUNAGA *

Abstract: Control systems achieve the desired performance with the model-based controller if the dynamical model of the actual plant is given with sufficient accuracy. However, if there exists a difference between the actual plant and its model dynamics, the model-based controller does not work well and does not achieve the intended desired performance. A model error compensator(MEC) is proposed for overcoming the model error in our previous study. Attaching the compensator for the model error to the actual plant, the output trajectory of the actual plant is made close to that of its model. Then, from the controller, the apparent difference in the dynamics can be smaller, and performance degradation is drastically reduced. MEC is useful for various control systems such as non-linear systems and the control systems with delay, and so on. In this paper, we propose an original design method of the filter parameters in MEC for systems with polytopic-type uncertainty and disturbances. First, we show an analysis method about the robust performance of MEC for the system with the polytopic type uncertainty based on an LMI problem. The gain parameters in MEC is designed using particle swarm optimization and the presented analysis method. The effectiveness of the design method for the system with polytopic-type uncertainty and disturbance is evaluated using numerical examples.

Key Words: Model error compensator, Robust control, H_∞ performance, Particle swarm optimization, Linear matrix inequalities

1. Introduction

Many control systems are designed by model-based control. First, we obtain a dynamical model of an actual plant by using system identification or physical modeling. Then, we design a controller for the nominal model. Finally, we obtain the desired control performance by applying the controller to the actual plant. Control systems achieve the intended output response with the model-based controller if the dynamical model of the actual plant is given with sufficient accuracy. On the other hand, the controller designed for the nominal model does not work if there are differences between actual plant dynamics and its model dynamics, such as modeling error, aging, and so on. In other words, the model-based control is weak against modeling errors and disturbances.

Robust control is a kind of control method that considers modeling errors and disturbances. However, it is difficult to come down to a mathematical problem from a complex design problem. Besides, the design results of robust control often become conservative performance because of robust control such as H_∞ control designs for a set of models.

A model error compensator (MEC) is proposed for overcoming the model error in the previous study[1]. The conventional robust control attaches robustness to the system by designing a controller that works well for all models in a set of models. On the other hand, MEC attaches robustness by attaching a compensator for the model error to the actual plant. The

MEC makes the output trajectory of the actual plant close to that of its nominal model. Then, from the controller, the apparent difference in the dynamics can be smaller, and performance degradation is reduced. As a result, it is expected that the system with MEC is more robust and can achieve better control performance where the controller is assumed to be designed by the existing design method. In other words, The systems with MEC can be together with various existing designed controllers. In the previous studies[2]–[4], application examples about welfare vehicles with MEC are presented. MEC is applied in the closed-loop system and is high accuracy compared to the system without MEC.

It is well known that disturbance observer[5]–[7] is one of the useful methods to make a part of the system robustly, and it is well used and effective. Its conceptual function is similar to MEC. If the given plant is a minimum phase and proper, we can make a disturbance observer with a modified inverse model, and the error of estimated disturbances approaches zero by designing the filter appropriately. However, for the non-minimum phase systems, the disturbance observer can not consist appropriately because the inverse system of the plant is unstable. In such a case, it is difficult to achieve good robust performance by using the disturbance observer. Moreover, it is also difficult to make an inverse system for many kinds of non-linear systems. On the other hand, MEC can be applied for non-minimum phase systems [8] and non-linear systems [9] without a complicated extension of the system.

The MEC is unique in that for simple systems such as the SISO system, the effect of modeling errors and disturbances are reduced by setting the gain with a little trial and error. However, we have to design the gain appropriately for many types of systems such as the MIMO system, the non-minimum phase system, and so on. The design method in the previous stud-

* Department of Computer Science and Electrical Engineering, Kumamoto University, Kumamoto, Japan
E-mail: yoshida@actrl.cs.kumamoto-u.ac.jp,
tanigawa@actrl.cs.kumamoto-u.ac.jp,
okajima@cs.kumamoto-u.ac.jp
(Received xxx 00, 2011)
(Revised xxx 00, 2011)

ies[1],[8] for these systems are mostly based on additive uncertainty, multiplicative uncertainty, and so on. However, the appropriate representation of uncertainty is different for each plant. Therefore, for the systems represented by various uncertainty, for example, the polytopic type uncertainty in state-space representation treated in this paper, a different framework to design MEC from previous studies is required. In addition, the design methods proposed in previous studies are based on frequency domain such as μ synthesis. However, when we evaluate the designed MEC in other evaluation indexes, such as the peak value of impulse response, the design method proposed in this paper is useful.

Therefore, in this paper, we propose a design method of parameters using particle swarm optimization(PSO)[10], which is one of the meta-heuristics methods. It is one of the advantages of meta-heuristics that they can alter the evaluation function flexibly. This means that we can design the MEC with an arbitrary evaluation index by setting the evaluation function according to the purpose. In this paper, the analysis method about the robust performance of MEC based on LMIs, which is shown in [11] is used as an evaluation function.

This paper is organized as follows: In chapter 2, the research outline of MEC is described. In chapter 3, an analysis method about H_∞ performance of MEC based on LMIs, which is used as an evaluation function in PSO, is shown. In chapter 4, we propose a design method combined with PSO and the analysis method. Finally, in chapter 5, we offer a numerical example of the proposed method. In this paper, we assume that the actual plant is a polytopic-type uncertain continuous LTI system.

Note that H_∞ norm of system G is given by the following equation.

$$\|G\|_\infty := \sup_{\omega \in R} \sigma_{\max}(G(j\omega)) \quad (1)$$

where, $\sigma(\cdot)$ is maximum singular value.

2. Model error compensator

In model-based control, we obtain the nominal model of an actual plant by system identification. Then, we design a controller for the nominal model, which achieves the desired control performance. However, if there is a modeling error, it is not able to achieve the desired control performance because it is designed for the nominal model. A model error compensator(MEC) is proposed for overcoming the model error effect in previous studies[1],[8]. MEC H is attached to plant P as shown in Fig.1. By designing MEC H appropriately, the influence of modeling error and disturbance is reduced, and the dynamics of P' is close to that of the nominal model. Therefore, from the controller, the apparent dynamics are close to the nominal model, and thus, the controller can achieve control performance as we designed. The controller is designed with various existing design methods. Hence the system which is applied MEC is expected to achieve superior robustness and control performance.

Fig.2 shows the basic structure of MEC, where P , P_m , and D are the actual plant, nominal model, and differential compensator, respectively. MEC H (represented by dashed dotted line in Fig.2) includes nominal model P_m inside and feedbacks the output difference of the actual plant P and the nominal model P_m . Here, we can make the dynamics of P' which represented

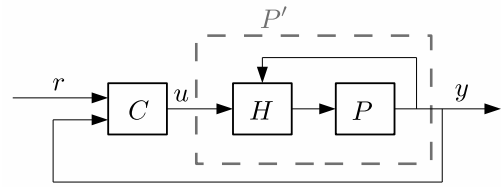

Fig. 1: Compensated system

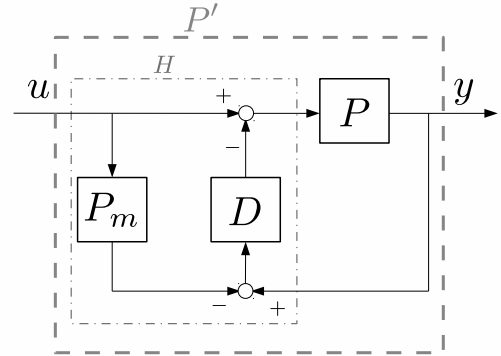

Fig. 2: Basic structure of MEC

by dashed line in Fig.2 close to P_m if appropriate differential compensator D is given.

Also, The MEC is unique in that it can be used in conjunction with conventional control systems. Fig.3 are some application examples of MEC. Fig.3a shows feedback system with MEC, Fig.3b shows state feedback system with MEC, and Fig.3c shows MPC with MEC. Like Fig.3, we can design the controller by various existing design methods. MEC manages the removal of the effects of modeling errors and disturbances, and the controller can be designed without considering them. This is effective when we compose a complex system, design a controller with MPC, and so on.

Now, we assume that the plant P is given as SISO and linear time invariant system. The transfer function from input u to output y is given as following equation:

$$P'(s) = \frac{1 + P_m(s)D(s)}{1 + P(s)D(s)} P(s) \quad (2)$$

where, consider the case that there is no modeling error, that is, $P(s) = P_m(s)$ is hold. The dynamics of $P'(s)$ is given as following equation:

$$\begin{aligned} P'(s)|_{P(s)=P_m(s)} &= \frac{1 + P_m(s)D(s)}{1 + P_m(s)D(s)} P_m(s) \\ &= P_m(s). \end{aligned} \quad (3)$$

From Eq.3, it is clear that if $P(s) = P_m(s)$ holds, differential compensator D does not affect the system.

If there is modeling error between P and P_m , it is desirable that the dynamics of system P' include differential compensator D is close to the nominal model P_m . The difference of the dynamics between P' and P_m is given as following equation:

$$\begin{aligned} P'(s) - P_m(s) &= \frac{1 + P_m(s)D(s)}{1 + P(s)D(s)} P(s) - P_m(s) \\ &= \frac{1}{1 + P(s)D(s)} (P(s) - P_m(s)). \end{aligned} \quad (4)$$

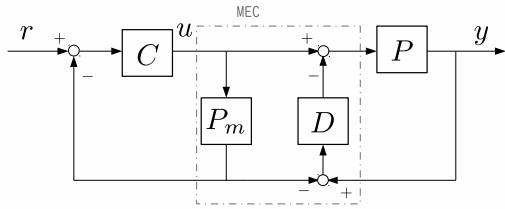

(a) FB system with MEC.

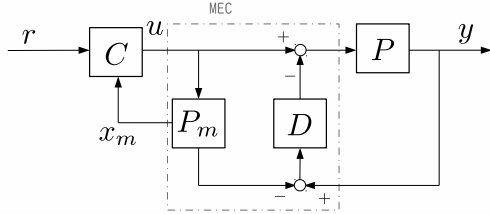

(b) State feedback system with MEC.

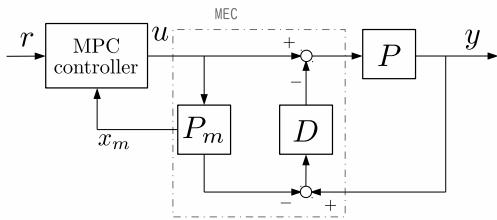

(c) MPC controller with MEC.

Fig. 3: Various control systems with MEC.

As shown in Eq.4, we can reduce the difference of the dynamics if differential compensator D is set to high gain. On the other hand, we have to design gain appropriately if the plant is MIMO, non-minimum phase, and so on.

Most of the previous studies[1],[8] proposed the design method of MEC based on frequency domain uncertainty, such as additive uncertainty, multiplicative uncertainty, and so on. Another framework is required if we design MEC for the systems with various uncertainty.

3. Analysis method about the robust performance of MEC

In this chapter, we explain the system representation of components of MEC and show the generalized plant to be analyzed robust performance. Then, we describe an analysis method of H_∞ performance of MEC. This analysis method is used for PSO as an evaluation function in this paper.

3.1 System representation of MEC

In this paper, we assume continuous-time linear time invariant system. The equation of state, which represents dynamics of the plant P is given by following equation:

$$\dot{x}(t) = Ax(t) + B\tilde{u}(t) + B_w w_u(t) \quad (5)$$

$$y(t) = Cx(t) + D_w w_y(t) \quad (6)$$

where t is the current time, A is a square matrix which represents dynamics of plant, also B , B_w , C , and D_w are appropriate matrices which are given depending on the number of the input/output. A , B , and C are assumed to have polytopic-type uncertainties and these are given as follows using $\lambda = [\lambda_i]$ and endpoint matrices A_i , B_i , and C_i with appropriate dimensions.

$$A = \sum_{i=1}^N \lambda_i A_i, B = \sum_{i=1}^N \lambda_i B_i, C = \sum_{i=1}^N \lambda_i C_i \quad (7)$$

where, λ is a time invariant parameter that belongs to the following set ε :

$$\varepsilon := \{\lambda \in R^N : \lambda_i \geq 0, \sum_{i=0}^N \lambda_i = 1\}. \quad (8)$$

The degree of the plant of Eq.5 is m_s , and $x(t) \in R^{m_s}$, $\tilde{u}(t) \in R^{m_i}$, $y(t) \in R^{m_o}$, $w_u(t) \in R^{m_{u_i}}$ and $w_y(t) \in R^{m_{o_i}}$ are the state, control input, plant output, disturbance input and observation noise, respectively. In this paper, it is assumed that the plant is controllable and observable about arbitrary $\lambda \in \varepsilon$.

Also, dynamics of the nominal model P_m which uses for MEC is given as continuous-time linear time invariant system by following equation:

$$\dot{x}_m(t) = A_m x_m(t) + B_m u_m(t) \quad (9)$$

$$y_m(t) = C_m x_m(t) \quad (10)$$

where, A_m is a square matrix which represents dynamics of the plant, also B_m and C_m are appropriate matrices which are given depending on the number of the input/output. $x_m(t) \in R^{m_s}$, $u_m(t) \in R^{m_i}$ and $y_m(t) \in R^{m_o}$ are the state of the nominal model, control input and nominal model output, respectively.

Now, we consider $\Delta A = A - A_m$, $\Delta B = B - B_m$, and $\Delta C = C - C_m$ that are the errors between the model and the actual plant. ΔA , ΔB , and ΔC are represented as follows using Eqs.7:

$$\Delta A = \sum_{i=1}^N \lambda_i \Delta A_i, \Delta B = \sum_{i=1}^N \lambda_i \Delta B_i,$$

$$\Delta C = \sum_{i=1}^N \lambda_i \Delta C_i.$$

where, $\Delta A_i = A_i - A_m$, $\Delta B_i = B_i - B_m$ and $\Delta C_i = C_i - C_m$.

When we consider that MEC is applied to the above plant P and the nominal model P_m , the differential compensator D is given by following equation:

$$\dot{x}_d(t) = A_d x_d(t) + B_d (y(t) - y_m(t)) \quad (11)$$

$$y_d(t) = C_d x_d(t) + D_d (y(t) - y_m(t)). \quad (12)$$

When we apply MEC to the plant, input to the nominal model is given as $u_m(t) = u(t)$, and input to the actual plant is given as $\tilde{u}(t) = u(t) - y_d(t)$, where $u(t)$ is the output of the controller C , and $y_d(t)$ is the compensation input.

3.2 Equation of state and evaluation output of the generalized plant

This section derives a generalized plant for the plant and the nominal model described in previous section. Fig.4 shows the generalized plant include MEC.

By defining $e(t) = x(t) - x_m(t)$, $\xi(t) = [e(t)^T, x_d(t)^T, x_m(t)^T]^T$ as state and $v(t) = [w_u(t)^T, w_y(t)^T, u(t)^T]^T$ as input, we obtain the following equations:

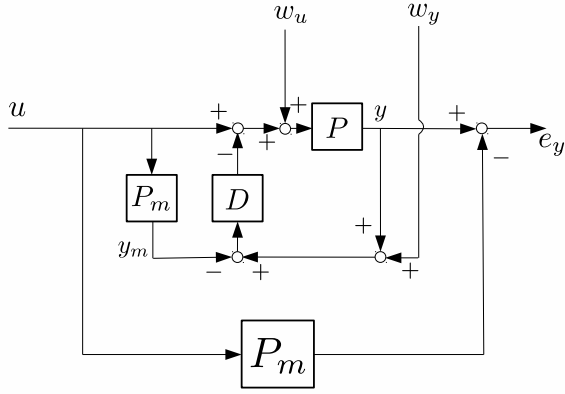
Fig. 4: Generalized plant G_e

$$\dot{\xi}(t) = \bar{A}\xi(t) + \bar{B}v(t) \quad (13)$$

$$\bar{A} = \begin{bmatrix} A - BD_dC & -BC_d & \Delta A - BD_d\Delta C \\ B_dC & A_d & B_d\Delta C \\ 0 & 0 & A_m \end{bmatrix} \quad (14)$$

$$\bar{B} = \begin{bmatrix} B_w & -BD_dD_w & \Delta B \\ 0 & B_dD_w & 0 \\ 0 & 0 & B_m \end{bmatrix} \quad (15)$$

where, the objective of MEC is making smaller the gap between y and y_m , hence, we consider following evaluation output:

$$e_y(t) = Cx(t) - C_m x_m(t) = \bar{E}\xi(t) \quad (16)$$

where $\bar{E} = [C, 0, \Delta C]$. Note that evaluation output $e_y(t)$ is not $y(t) - y_m(t)$ but excluded observation noise from $y(t) - y_m(t)$.

Besides, to analyze based on polytopic-type uncertain, we define the following matrices:

$$\bar{A}_i = \begin{bmatrix} A_i - B_iD_dC_i & -B_iC_d & \Delta A_i - B_iD_d\Delta C_i \\ B_dC_i & A_d & B_d\Delta C_i \\ 0 & 0 & A_m \end{bmatrix}$$

$$\bar{B}_i = \begin{bmatrix} B_w & -B_iD_dD_w & \Delta B_i \\ 0 & B_dD_w & 0 \\ 0 & 0 & B_m \end{bmatrix}$$

$$\bar{E}_i = [C_i \quad 0 \quad \Delta C_i], \quad (i = 1, \dots, N)$$

where, 1,1 element of \bar{A}_i includes bilinear term of B_i and C_i , and 1,3 element of \bar{A}_i includes bilinear term of B_i and ΔC_i . Therefore, it cannot be a matrix polytope, but if $\Delta B = 0$, $\Delta C = 0$ or $D_d = 0$ is satisfied, then we can obtain following equation which represents the dynamics of generalized plant as matrix polytope using \bar{A}_i , \bar{B}_i , \bar{E}_i and $\lambda \in \varepsilon$:

$$\bar{A} = \sum_{i=1}^N \lambda_i \bar{A}_i, \bar{B} = \sum_{i=1}^N \lambda_i \bar{B}_i, \bar{C} = \sum_{i=1}^N \lambda_i \bar{C}_i. \quad (17)$$

The output of systems often represents the state as it is, and these systems satisfy $\Delta C = 0$. Also, $D_d = 0$, which means there is no direct term in the differential compensator, is often used in many previous control systems design theories. Therefore, to satisfy the assumption is not difficult.

Also, the input-output system from $v(t)$ to $e_y(t)$ is expressed as G_e . The system G_e is affected by not only disturbance input and observation noise but also input u .

3.3 Analysis about H_∞ performance using LMIs

This section describes the analysis method about H_∞ performance about system G_e obtained in the previous section. In this section, we assume that $\Delta B = 0$, $\Delta C = 0$, or $D_d = 0$ is hold about the system G_e given by Eq.13. As described before, under this assumption, the input and output of the system G_e can be represented by polytopic matrices, and we can easily analyze the system.

First, for the endpoint matrices $(\bar{A}_i, \bar{B}_i, \bar{E}_i)$, analysis problem about H_∞ performance is obtained as the following LMIs using given $\gamma_\infty > 0$:

$$X > 0, \begin{bmatrix} \bar{A}_i X + X \bar{A}_i^T & X \bar{E}_i^T & \bar{B}_i \\ \bar{E}_i X & -\gamma_\infty^2 I & 0 \\ \bar{B}_i^T & 0 & -I \end{bmatrix} < 0. \quad (18)$$

Where, let LMI constraints of Eqs.18 denote as $\Psi_i < 0$, and if we find $X > 0$ which satisfies $\Psi_i < 0$ for all i , noting that $\lambda_i \geq 0$, the following inequality is hold:

$$\left(\sum_{i=1}^N \lambda_i \Psi_i \right) < 0 \quad (19)$$

From $\sum_{i=1}^N \lambda_i = 1$, Eqs.17,18 and 19, following LMIs are hold:

$$X > 0, \begin{bmatrix} \bar{A} X + X \bar{A}^T & X \bar{E}^T & \bar{B} \\ \bar{E} X & -\gamma_\infty^2 I & 0 \\ \bar{B}^T & 0 & -I \end{bmatrix} < 0. \quad (20)$$

If X and γ_∞ , which satisfy Eq.20 are found, system G_e holds the following inequality:

$$\|G_e\|_\infty \leq \gamma_\infty. \quad (21)$$

Therefore, by finding the minimum γ_∞ satisfying Eq.20, we can analyze system G_e about H_∞ performance. In other words, the analysis problem about H_∞ is coming down to the problem to find a minimum γ_∞ which satisfy Eq.20. This problem can be solved easily with numerical calculations software such as MATLAB.

H_∞ norm is equal to L_2 induced norm, so following equation is established:

$$\|G_e\|_\infty = \sup_{v \in L_2, \|v\|_2 \neq 0} \frac{\|e_y\|_2}{\|v\|_2}. \quad (22)$$

In this way, we give the analysis method of MEC about H_∞ performance.

In this paper, we described the analysis method about only H_∞ performance. However, also, LMI constraints of H_2 performance, the peak value of impulse response, and pole placement are described in [20]. Therefore, we can obtain these evaluation indexes by setting these constraints and design MEC using these indexes.

4. Design method of MEC using PSO

As we described in the previous chapter, if the parameters of differential compensator D is given, we can analyze the H_∞ performance of generalized plants G_e . Hence, we provide the parameters with meta-heuristics such as particle swarm optimization(PSO), and the results of the analysis are used for evaluation value in the proposed method. This chapter describes

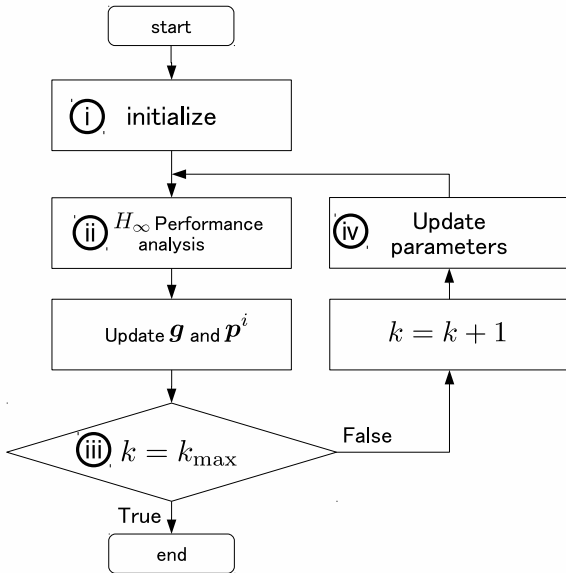

Fig. 5: Flowchart of MEC design using PSO

the design method of MEC combining PSO with the analysis method about the H_∞ performance of MEC.

PSO is a multi-point search algorithm that simulates search behavior such as fishes and birds. It is well known that PSO is useful for control system design. PSO has the following features: the concept is easy to understand, few parameters to set by the user, and suitable for searching real number variable, which has continuous value.

Also, meta-heuristics can be changed the evaluation function flexibly. That is, meta-heuristics can evaluate various indexes; thus, we can design according to the purpose.

Fig.5 shows the flowchart of a procedure to obtain parameters of the differential compensator D . Where the evaluation value is set to γ_∞ obtained by the analysis method described in the previous section, which is H_∞ performance. Note that as described before, we can set the evaluation value as not only H_∞ norm but also H_2 norm, the peak value of impulse response, and so on. The position and velocity of i -th particle ($i = 1 \cdots m$) are denoted by $z_x^i(k) = (z_{x1}^i(k), \cdots, z_{xn}^i(k))$ and $z_v^i(k) = (z_{v1}^i(k), \cdots, z_{vn}^i(k))$, respectively. Where n is the number of parameters to be designed, m is the number of particles, and k is the update count. The position means a set of the design parameters in the differential compensator D , and we obtain the evaluation value by analyzing MEC using the parameters. The best solution found by whole particles, which is the position that best evaluation value is achieved, is denoted by $g = (g_1, g_2, \cdots, g_n)$. Also, the best solution found by i -th particle, which means the position that best evaluation value is obtained by i -th particle is denoted by $p^i = (p_1^i, p_2^i, \cdots, p_n^i)$. The maximum update count is set as k_{\max} . Details of each step are described below.

- ① This process initializes variables: Set update count k to 0. Also set the position $z_x^i(0) = (z_{x1}^i(0), \cdots, z_{xn}^i(0))$ and velocity $z_v^i(0) = (z_{v1}^i(0), \cdots, z_{vn}^i(0))$ of i -th particle to random value. Then, we solve LMIs given by Eq.20 and obtain a evaluation value. Sometimes the evaluation value can not obtain because the LMIs has no solution depending on the initialized value. In that case, set z_x^i and z_v^i to

random value again until the LMIs is solvable. p^i is set to the i -th particle position and g is set to p^i that best evaluation value is achieved from whole particles.

- ② Evaluate each particle using an analysis method about H_∞ performance of MEC described in the previous chapter. If the LMIs have no solution, it means that the generalized plant is unstable, therefore the evaluation value of the particle sets to a large value as a penalty.

- ③ Determine completion: If update count k does not reach maximum update count k_{\max} , do $k = k + 1$ then proceed to parameters update. If update count k reaches maximum update count k_{\max} , output g as the optimal parameters of differential compensator D , then end the search.

- ④ Update position and velocity parameters with the following equation:

$$z_x^i(k+1) = z_x^i(k) + z_v^i(k) \quad (23)$$

$$z_v^i(k+1) = \rho z_v^i(k) + r_{1,i} c_1 (p^i - z_x^i(k)) + r_{2,i} c_2 (g - z_x^i(k)) \quad (24)$$

where, ρ is a weighting factor for velocity vector before the update. c_1 and c_2 are weighting factor for each term. $r_{1,i}$ and $r_{2,i}$ are random numbers from 0 to 1 and it is generated for each particle and update count.

It is not so difficult to obtain the initialized values in ① when the number of the design parameters is not so large. To decrease the number of the parameters, it is useful to design the differential compensator D as a controllable canonical form described later in Sect 5.1. Also, the differential compensator D can be designed as a PID compensator, and like these, we can decrease the number of parameters to design. In the process of PSO, sometimes a part of solutions becomes infeasible when the position $z_x^i(k)$ is updated. At that time, the evaluation value of the infeasible solution is set to a very large value as a penalty. Therefore, infeasible solutions do not affect other candidates of solutions.

5. Simulation

This chapter shows a numerical example of the design of MEC for the MIMO plant.

5.1 Conditions

The dynamics of actual plant represented by Eqs.5 and 6 is given by following matrices as $N = 4$:

$$A_1 = \begin{bmatrix} 0 & -1 & 1 \\ 0 & -1.6 & 2 \\ 0 & 1 & -4.8 \end{bmatrix} A_2 = \begin{bmatrix} -0.4 & -1 & 1 \\ 0 & -2.4 & 2 \\ 0 & 1 & -5.2 \end{bmatrix}$$

$$A_3 = \begin{bmatrix} -0.2 & -1.2 & 1 \\ 0 & -2 & 2.2 \\ 0.2 & 1 & -5 \end{bmatrix} A_4 = \begin{bmatrix} -0.2 & -0.8 & 1 \\ 0 & -2 & 1.8 \\ -0.2 & 1 & -5 \end{bmatrix}$$

$$B_1 = \begin{bmatrix} 1 & 0 \\ -1 & 1 \\ 2.6 & 5 \end{bmatrix} B_2 = \begin{bmatrix} 1 & 0 \\ -1 & 1 \\ 1.4 & 5 \end{bmatrix}$$

$$B_3 = \begin{bmatrix} 1.2 & 0 \\ -0.8 & 1 \\ 2 & 5 \end{bmatrix} B_4 = \begin{bmatrix} 0.8 & 0 \\ -1.2 & 1 \\ 2 & 5 \end{bmatrix}$$

$$C_1 = C_2 = C_3 = C_4 = \begin{bmatrix} 1 & 0.5 & 0 \\ 1 & 1 & 1 \end{bmatrix}$$

$$B_w = \begin{bmatrix} 0.1 & 0 \\ -0.1 & 0.1 \\ 0.2 & 0.5 \end{bmatrix} D_w = \begin{bmatrix} 0.01 & 0 \\ 0 & 0.01 \end{bmatrix}.$$

The nominal model matrices A_m , B_m and C_m are given as follows:

$$A_m = \begin{bmatrix} -0.2 & -1 & 1 \\ 0 & -2 & 2 \\ 0 & 1 & -5 \end{bmatrix} B_m = \begin{bmatrix} 1 & 0 \\ -1 & 1 \\ 2 & 5 \end{bmatrix}$$

$$C_m = \begin{bmatrix} 1 & 0.5 & 0 \\ 1 & 1 & 1 \end{bmatrix}$$

where, the nominal model is the center of endpoint matrices of the plant, that means $\lambda_i = 0.25$ ($i = 1, \dots, 4$).

Also, differential compensator D is designed with the controllable canonical form like the following matrices:

$$A_d = \begin{bmatrix} 0 & 1 & 0 \\ z_{x1} & z_{x2} & z_{x3} \\ z_{x4} & z_{x5} & z_{x6} \end{bmatrix} B_d = \begin{bmatrix} 0 & 0 \\ 1 & z_{x7} \\ 0 & 1 \end{bmatrix} \quad (25)$$

$$C_d = \begin{bmatrix} z_{x8} & z_{x9} & z_{x10} \\ z_{x11} & z_{x12} & z_{x13} \end{bmatrix} D_d = \begin{bmatrix} z_{x14} & z_{x15} \\ z_{x16} & z_{x17} \end{bmatrix}$$

By designing with a controllable canonical form, the number of variables to design decreases, therefore the number of dimensions to search decreases, and efficient search is expected.

Maximum update count k_{\max} sets to 100 and the number of particles set to 50. The weighting factor ρ , c_1 and c_2 set to 0.8, 1 and 1, respectively.

The initial values of the position and the velocity are randomly selected in the ranges we set. These are set to $[-10000, 10000]$ and $[-10, 10]$, respectively. Considering that MEC reduces the influences of disturbances and modeling errors by high gain feedback, the range of initial value of the position is set to large compared with the velocity.

5.2 Design results of MEC

The following is the design results of differential compensator D for the plant described in the previous section:

$$A_d = \begin{bmatrix} 0 & 1 & 0 \\ -6876.04 & -2314.40 & 5421.53 \\ 9503.05 & -1406.48 & -8845.41 \end{bmatrix} \quad (26)$$

$$B_d = \begin{bmatrix} 0 & 0 \\ 1 & -5273.36 \\ 0 & 1 \end{bmatrix} \quad (27)$$

$$C_d = \begin{bmatrix} 237.54 & -7261.59 & 4367.41 \\ -6771.48 & -7585.91 & -4548.58 \end{bmatrix} \quad (28)$$

$$D_d = \begin{bmatrix} 3536.44 & -342.39 \\ -1868.22 & 7496.95 \end{bmatrix} \quad (29)$$

where, apply the above differential compensator D to plant and analyze the generalized plant G_e . Then we obtain $\gamma_\infty = 0.0167$, therefore following formula holds:

$$\|G_e\|_\infty \leq 0.0167. \quad (30)$$

Note that the design result may have large negative poles or be high gain. However, there is no problem for practical usage. If these have to be small due to some constraints, we can impose these easily, and this is one of the advantages of using the meta-heuristics design method.

5.3 Verify the design results

We compose MEC shown in Fig.2 using differential compensator D designed in the previous section to verify the effectiveness of the design method. The actual plants are given randomly by selecting multiple points in the polytope, and simulations are performed for these plants.

The control input u is given as 0.2 from $t = 0$ to 20. Disturbance input and observation noise are given as random noise, which inputs from $t = 0$ to 20 and follows the normal distribution with average set to 0 and standard deviation set to 1. Fig.6 shows the response of the systems with MEC, each plant only, and ideal. As shown in Fig.6, for the plants in the polytope, designed MEC reduces the influence of the random noise. Also, Fig.7 shows the evaluation outputs of the plant in the polytope with the noise. As shown in Fig.7, designed MEC improves the evaluation output compared to the system without MEC. The ratio of L_2 norm from the random noise to the evaluation output is obtained as $\|e_y\|_2/\|v\|_2 = 0.0070$ and it satisfies the analysis result Eq.30.

In addition, the control input u is given as 0.2 from $t = 0$ to 20. Disturbance input and observation noise are given as 0.2 from $t = 10$ to 20. Fig.8 shows the response of the systems with MEC, each plant only, and ideal. From Fig.8, for the plants in the polytope, designed MEC reduces the influence of the step type disturbance. Also, Fig.9 shows the evaluation outputs of a plant in the polytope to the step type disturbance and designed MEC improves the evaluation output. The ratio of L_2 norm of evaluation output to the step type disturbance is obtained as $\|e_y\|_2/\|v\|_2 = 0.0049$ and this satisfies the analysis result Eq.30.

It is shown that MEC designed by the proposed method works well and reduces the influence of the disturbances and modeling errors.

6. Conclusions

In this paper, we proposed a design method of MEC combining particle swarm optimization with an analysis method about H_∞ performance of MEC. First, a system representation

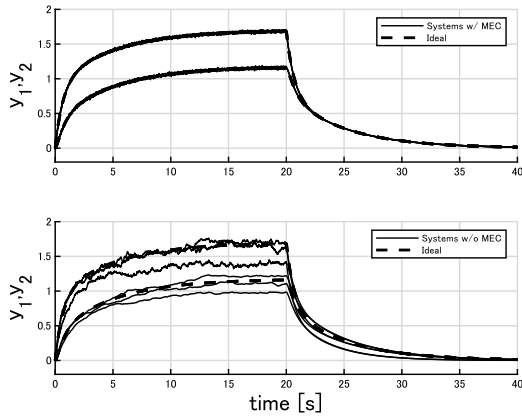

Fig. 6: Response to random disturbance.

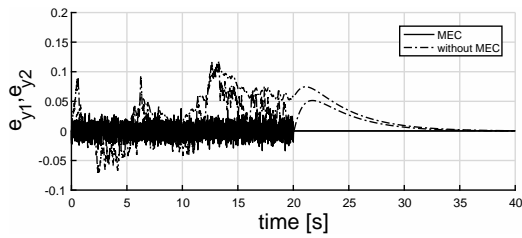

Fig. 7: Evaluation outputs to random disturbance.

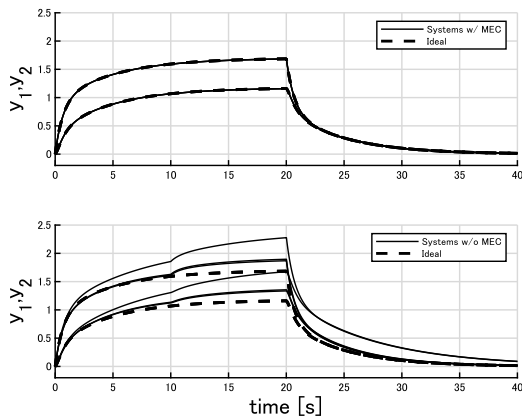

Fig. 8: Response to step type disturbance.

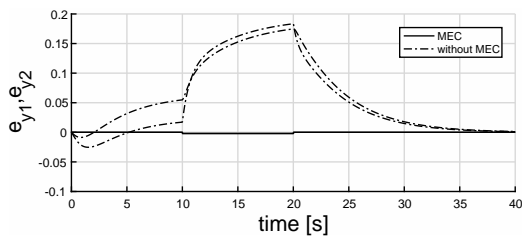

Fig. 9: Evaluation outputs to step type disturbance.

of components of MEC is given, and generalized plants G_e is derived. Then, we described the analysis method about H_∞ performance of generalized plants based on LMIs. The analysis method with LMIs is used as an evaluation scheme in the proposed method. By altering the evaluation function, we can also design MEC according to the purpose. For example, analysis conditions of H_2 performance, the peak value of impulse response, and pole placement are derived as LMIs[20]; thus, we can set the evaluation function to the evaluation index. Finally, a MEC design example is shown in numerical simulation. We compose MEC using the design result and show response

waveform to the random and step disturbances. It shows that designed MEC can reduce the influence of them. Also, we confirmed that the system with MEC satisfies the analysis result.

Future work will apply the proposed method to the non-minimum phase system and unstable system. In previous studies, it is suggested that the compensation structure of MEC, which uses a parallel feed-forward compensator for the non-minimum phase system. For unstable systems, we can design MEC by designing a controller, which makes the plant stable in advance. Thus, it is expected that the proposed method in this paper is applied to the non-minimum phase system and unstable system by deriving the generalized plant, including a parallel feed-forward compensator and the MEC, respectively.

References

- [1] H.Okajima, H.Umei, N.Matsunaga and T.Asai, A Design Method of Compensator to Minimize Model Error, *SICE Journal of Control, Measurement, and System Integration*, Vol. 6, No. 4, pp. 267-275, 2013.
- [2] N.Matsunaga, S.Sakamoto, T.Tanaka, and H.Okajima, Design of driving assistance control for personal skid steer vehicle with model error compensator and its evaluation of outdoor driving, *Transactions of the JSME (in Japanese)*, Vol. 84, No. 858, 17-00349, 2018
- [3] Y.Maruno, A.T.Zengin, H.Okajima, N.Matsunaga, and N.Nakamura, Maneuverability Improvement of Front-Drive Personal Welfare Vehicle STAVi Using a Model Error Compensator, *Transactions of the Japan society of mechanical engineers. C*, Vol. 79, No. 808, pp. 4721-4733, 2013
- [4] T.Sugino, Y.Dan, H.Okajima, and N.Matsunaga, Evaluation of robust indoor platoon driving system of welfare personal vehicles by using model error compensator, *Transactions of the JSME (in Japanese)*, Vol. 82, No. 840, 15-00690, 2016
- [5] S. Komada, M. Ishida, K. Ohnishi, and T. Hori: Disturbance observer-based motion control of direct drive motors, *IEEE Transactions on Energy Conversion*, Vol. 6, No. 3, pp. 553-559, Sept. 1991
- [6] Z. Ding: Consensus Disturbance Rejection With Disturbance Observers, *IEEE Transactions on Industrial Electronics*, Vol. 62, No. 9, pp. 5829-5837, Sept. 2015
- [7] K. Kim, K. Rew, and S. Kim: Disturbance Observer for Estimating Higher Order Disturbances in Time Series Expansion, *IEEE Transactions on Automatic Control*, Vol. 55, No. 8, pp. 1905-1911, Aug. 2010
- [8] G.Ichimasa, H.Okajima, K.Okumura and N.Matsunaga: Model Error Compensator with Parallel Feed-forward Filter, *SICE Journal of Control, Measurement, and System Integration*, Vol. 10 No. 5, pp. 468-475, 2017.
- [9] H.Okajima, Y.Nishimura and N.Matsunaga: A Feedback Linearization Method for Non-linear Control Systems Based on Model Error Compensator, *Transactions of the Society of Instrument and Control Engineers*, Vol. 50, No. 12, pp. 869-874, 2014.
- [10] M. Clerc and J.Kennedy: The particle swarm - explosion, stability, and convergence in a multidimensional complex space, *IEEE Transactions on Evolutionary Computation*, Vol. 6, No. 1, pp. 58-73, 2002.
- [11] H. Okajima: Analysis of Robust Performance of Model Error Compensator for Polytopic-type Uncertain Continuous-time Linear Time Invariant Systems, *Transactions of the Society of Instrument and Control Engineers*, Vol. 55, No. 12, pp. 800-807, 2019.
- [12] T. Sano and S. Yamamoto: A Data-Driven Tuning Method for Model Error Compensator, *Proc. SICE 2018*, pp. 1199-2002, 2018.
- [13] H. Endo, R. Aramaki, K. Sekiguchi and K. Nonaka: Appli-

cation of Model Error Compensator Based on FRIT to Quadcopter, *2017 IEEE Conference on Control Technology and Applications*, pp. 1724-1915, 2017.

- [14] D. Koyama, K. Hashikura, M. A. S. Kamal and K. Yamada: Low-sensitivity Control with Robust Stability Using Double-feedback Control for MIMO Time-Delay Systems, *International Journal of Innovative Computing, Information and Control*, Volume 16, Number 4, pp. 1133-1146, 2020.
- [15] M. Morari and E. Zafiriou: *Robust Process Control*, Prentice Hall, 1989.
- [16] K. Gu and N. K. Loh: Direct computation of stability bound for systems with polytopic uncertainties, *IEEE Transactions on Automatic Control*, Vol. 38, No. 2, pp. 363-366, Feb. 1993
- [17] U. Shaked: Improved LMI representations for the analysis and the design of continuous-time systems with polytopic type uncertainty, *IEEE Transactions on Automatic Control*, Vol. 46, No. 4, pp. 652-656, April 2001
- [18] Y. He, M. Wu, and J.-H. She: Improved bounded-real-lemma representation and H_{∞} control of systems with polytopic uncertainties, *IEEE Transactions on Circuits and Systems II: Express Briefs*, Vol. 52, No. 7, pp. 380-383, July 2005
- [19] Raheleh Nazari, Maria M. Seron, Joso A. De Dona: Actuator fault tolerant control of systems with polytopic uncertainties using set-based diagnosis and virtual-actuator-based reconfiguration, *Automatica*, Volume 75, 2017, Pages 182-190,
- [20] Y. Ebihara, *System Control Based on LMIs: Systematic Approach for Robust Control*, Morikita Publishing, 2013.

.....

Ryuichiro YOSHIDA (Student Member)



He received his B.E. from Kumamoto University, Japan, in 2020. He is currently a master's student at Kumamoto University. His research interests include control systems design.

Yuki TANIGAWA (Student Member)



He received his B.E. from Kumamoto University, Japan, in 2019. He is currently a master's student at Kumamoto University. His research interests include control systems design.

Hiroshi OKAJIMA (Member)



He received his M.E. and Ph.D. degrees from Osaka University, Japan, in 2004 and 2007, respectively. He is presently an associate professor at Kumamoto University, Japan. His research interests include tracking control, analysis of non-minimum-phase systems, and data quantization for networked systems. He is a member of ISCIE and IEEE.

Nobutomo MATSUNAGA (Member)



He received M.D. and Ph.D. degrees from Kumamoto University, Japan, in 1987 and 1993, respectively. He joined OMRON(Corp.) in 1987. Since 2002, he has been with the Department of Computer Science and Electrical Engineering, Kumamoto University, where he is a Professor. His research interests include thermal process control, automotive control, and human-machine system design. He is a member of IEEJ and IEEE.

.....