

Model Error Compensator with Parallel Feed-Forward Filter

Gou ICHIMASA *, Hiroshi OKAJIMA *, Kosuke OKUMURA *, and Nobutomo MATSUNAGA *

Abstract: Design methods for control systems based on plant models have been developed for many years. If a mathematical model is accurately obtained from the input-output relation of a plant, then the designed controller for the model performs well for the control system connected with the plant. However, the desired control performance might not be achieved when there is an undeniable modeling error. To overcome this problem, the authors proposed the model error compensator(MEC) to minimize the effect of the modeling error between the plant and model. The MEC works well for many control systems, such as unstable systems and non-linear systems. However applying the MEC to non-minimum-phase plants is difficult because of their control system structures. Non-minimum-phase plants are well known for being difficult to control. This paper proposes an MEC with a parallel feed-forward filter(PFF). The PFF is used to cancel the non-minimum-phase characteristics of the plant. The effectiveness of the proposed method is illustrated through numerical examples.

Key Words: Internal model control, Non-minimum-phase system, Model error compensator.

1. Introduction

Design methods for control systems based on plant models have been developed for many decades. If there is no modeling error between the plant and its model, the desired output can be achieved using the designed controller. However, the desired output might not be achieved when there exists a modeling error because of the variation of the plant parameters and the approximation errors.

A model error compensator(MEC) has been proposed for overcoming the effect of the modeling error[1]. The MEC comprises a model component and an error feedback component. It works to minimize the modeling error between the plant and the model. The plant compensated by the MEC is used instead of the plant itself. If the compensated plant is similar to the model in its input-output relations, it can be expected to achieve a desired output by applying the designed controller for the model. The MECs have shown effectiveness when used for electric wheelchair control[2], vibration control[3], non-linear[4] and multiple-input/multiple-output(MIMO) systems[5].

In previous research[1], the MEC has minimized the modeling error when a high gain compensator is designed. Therefore, it is difficult to apply the MECs to the non-minimum-phase plants having time delays or unstable zeros as this would require designing a high gain compensator, which is challenging for such systems.

This paper proposes an MEC with a parallel feed-forward filter(PFF). In the simple adaptive control(SAC), the PFF is a filter that compensates a plant characteristics to allow for easy design of the controller[6]–[11]. In this paper, a PFF is used to overcome the non-minimum-phase characteristics of the plant. If the PFF that overcome such characteristics is designed, the MEC compensator regards the extended plant comprising the

plant and the PFF as a minimum-phase plant. As a result, designing a compensator with high model error suppression performance is desirable. The effectiveness of the proposed method is illustrated through numerical examples.

2. Model error compensator

2.1 Basic idea

The basic idea of the standard MEC[1] is presented in this section.

In the model-based control systems design, control systems are designed through the following steps. First, a nominal model is derived from the output of a plant and physical laws. Next, a controller for the derived model P_m is designed as shown in the upper part of Fig. 1. The output y_m in Fig. 1 is the ideal output. Finally, the designed controller is applied to the plant P as shown in the lower part of Fig. 1.

When there is no difference between the nominal model and the plant, the ideal output y_m is obtained as the actual output y by using the controller designed by existing studies. However, if the dynamics of the model and the plant are not similar, the actual output y is not similar to the ideal output y_m . Therefore, it is necessary to suppress the model error between the nominal model and the plant.

To minimize the model error, we have considered a compensated system, as shown in Fig. 2. The compensator $H(s)$ suppresses the model error between the nominal model $P_m(s)$ and the compensated system $P_c(s)$. A control system structured by using the compensated system $P_c(s)$ instead of $P(s)$ is shown in Fig. 3. If the model error between $P_m(s)$ and $P_c(s)$ is minimized by the compensator $H(s)$, then the output of the compensated system $P_c(s)$ is similar to that of the nominal model $P_m(s)$. Therefore, the ideal output is obtained when there exists the model error between the nominal model and the plant.

2.2 Structure of MEC

In this section, the structure of the MEC is explained.

The standard structure of the MEC[1] is shown in Fig.4. In

* Graduate School of Science and Technology, Kumamoto University, Kumamoto 860-8555, Japan
E-mail: okajima@cs.kumamoto-u.ac.jp
(Received xxx 00, 2011)
(Revised xxx 00, 2011)

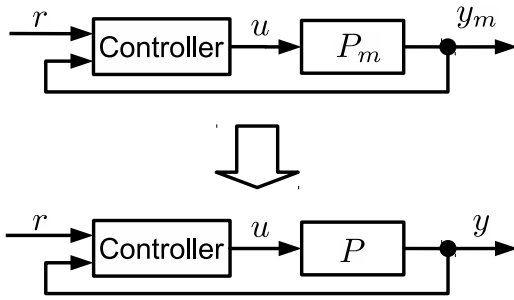

Fig. 1 Standard design sequence of model-based control

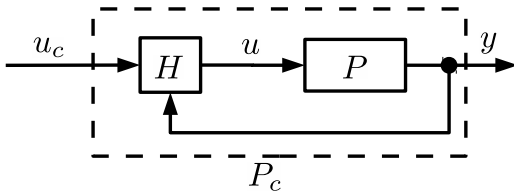

Fig. 2 Compensated system

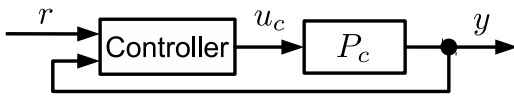

Fig. 3 Control system using system shown in Fig.2

this figure, $P(s)$ is the plant, $D(s)$ is the differential compensator and $P_m(s)$ is the nominal model of the plant $P(s)$.

The difference between y and y_n is used as the feedback signal and the compensator $D(s)$ reduces its model error. The transfer function from u_c to y can be represented as follows:

$$P_c(s) = P(s) \frac{1 + P_m(s)D(s)}{1 + P(s)D(s)}. \quad (1)$$

When the plant $P(s)$ is equal to the nominal model $P_m(s)$, the transfer function becomes $P_m(s)$ for any $D(s)$. This fact can be confirmed from Eq. (1).

On the other hand, if there exists a model error $\Delta_p(s)$ between $P(s)$ and $P_m(s)$, the MEC suppresses the effect for outputs by the error. When $P(s)$ is represented as $P_m(s) + \Delta_p(s)$, the difference between the compensated system $P_c(s)$ and $P_m(s)$ can be written as follows.

$$P_c(s) - P_m(s) = \frac{1}{1 + P(s)D(s)} \Delta_p(s) \quad (2)$$

Following Eq. (2), the MEC minimizes the modeling error when a high gain compensator $D(s)$ is designed[1]. The design method of compensator $D(s)$ which is shown in Fig.4 was presented in [1].

The MEC has similar concept of the disturbance observer. In case of the disturbance observer, an inverse model of the plant is required to compensate the effect of the disturbance and the model error. It is difficult to apply disturbance observer to such as non-linear systems, MIMO systems and non-minimum-phase systems. On the other hand, the MEC does not need the inverse model of the plant in the compensator. Therefore, design degree of freedom is larger in the MEC. The MEC showed effectiveness for electric wheelchair control[2], vibration control[3], non-linear systems[4] and MIMO systems[5].

However, it is difficult to apply the MEC to the non-minimum-phase plants with time delays or unstable zeros, be-

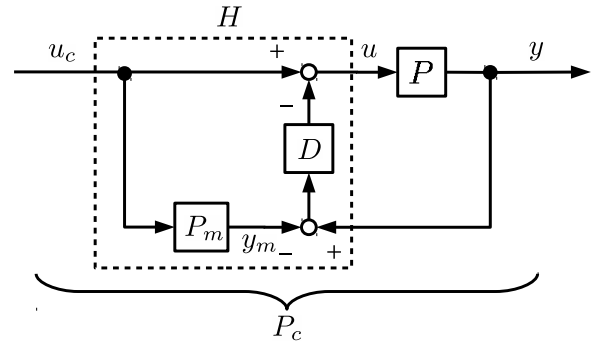

Fig. 4 Block diagram of standard MEC

cause the high gain compensator has difficulty stabilizing the non-minimum-phase systems. Therefore, applying the MEC to the non-minimum-phase plants in [1] is left to future works. In this paper, a new structure for minimizing the model error for the non-minimum-phase plants is proposed.

3. Main result

3.1 Non-minimum-phase plants and model

Plants with non-minimum-phase characteristics are described by the following equation.

$$P(s) = P_0(s)e^{-Ls} \prod_{i=1}^N \frac{s - z_i}{s + \bar{z}_i} + \Delta_p(s) \quad (3)$$

$P_0(s)$ is a transfer function of a stable minimum-phase system, z_i represents unstable zeros, \bar{z}_i is the complex conjugate of z_i , and L expresses the time delay. Plants with no time delay can be expressed by $L = 0$. If plants have no unstable zeros, then N is set to zero to express the plant characteristics. $\Delta_p(s)$ is an additional model error. Moreover, the nominal model is given as follows.

$$P_m(s) = P_0(s)e^{-Ls} \prod_{i=1}^N \frac{s - z_i}{s + \bar{z}_i} \quad (4)$$

3.2 MEC with PFF

In this section, the proposed structure of an MEC using a PFF is explained. Fig.5 shows the proposed structure of the MEC. $D(s)$ is a compensator and $F(s)$ is a PFF. In Fig.4, the feedback signals to the compensator $D(s)$ are generated from the difference between y and y_m . Meanwhile, in Fig.5, the difference between y_f and y_{mf} is used as the feedback signal. The transfer function from u_c to $y(s)$ is described by the following equation.

$$P_c(s) = P(s) \frac{1 + (P_m(s) + F(s))D(s)}{1 + (P(s) + F(s))D(s)} \quad (5)$$

In case the plant is equivalent to the nominal model ($P_m(s) = P(s)$), the transfer function becomes $P(s)$ for any $D(s)$ from Eq. (5). Moreover, if $P_m(s) + F(s)$ becomes a stable minimum-phase system, the design problem of $D(s)$ can be handled in the same framework as in previous research[1]. Therefore, it is necessary to design a compensator $D(s)$ that has high model error suppression performance.

Here, the design conditions of $F(s)$ and $D(s)$ are as follows:

C1: The difference between $P_{cf}(s)$ and $P_m(s)$ is suppressed.

C2: $P_{cf}(s)$ is stable for any given $P(s)$.

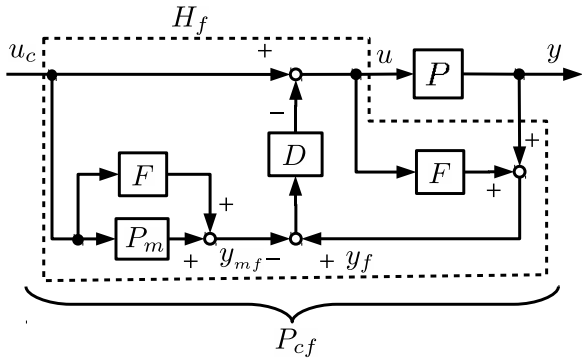

Fig. 5 Block diagram of proposed MEC with PFF

C1 and C2 are the same conditions as in previous research [1]. The main purpose is to satisfy C1. C2 concerns with the stability of the entire compensator.

First, C1 is considered. When the plant $P(s)$ involves a model error $\Delta_P(s)$ ($P(s) = P_m(s) + \Delta_P(s)$), the difference between $P_{cf}(s)$ and $P_m(s)$ is written as

$$P_{cf}(s) - P_m = \gamma(s)\Delta_P(s) \quad (6)$$

where $\gamma(s)$ is described as

$$\gamma(s) = \frac{1 + F(s)D(s)}{1 + (P(s) + F(s))D(s)} \quad (7)$$

From Eq. (6), the model error is suppressed by minimizing $\gamma(s)$. Thus, the following evaluation function J is introduced:

$$J = \sup_{\Delta_P} \|W_e \gamma\|_\infty \quad (8)$$

where $W_e(s)$ is a weighting function. If the evaluation function J is minimized, the model error can be suppressed.

Next, C2 is considered in order to satisfy robust stability. If the stability condition of the loop transfer function $D(s)(P(s) + F(s))$ is satisfied, then $P_{cf}(s)$ is stable for any $P(s)$.

3.3 Design of filters in proposed systems

In this section, first, the design method of the PFF $F(s)$ for overcoming the non-minimum-phase characteristics is shown. Next, the design method of compensator $D(s)$ is explained using the designed $F(s)$.

3.3.1 Design of $F(s)$

The design method of the PFF $F(s)$ is considered when the plant defined in Eq. (3) is (i) $n \neq 0, L = 0$, (ii) $n = 0, L \neq 0$ and (iii) $n \neq 0, L \neq 0$ respectively.

First, case (i) $n \neq 0, L = 0$ is considered. When $F(s)$ is added to the nominal model $P_m(s)$, the system $P_m(s)$ with $F(s)$ must become the transfer function of the minimum-phase characteristics. Here, if $D(s)$ is set to high gain, then minimizing $W_e(s)F(s)/(P_m(s)+F(s))$ is effective for the minimization problem of J . Consequently, $F(s)$ is designed using the following evaluation function:

$$\mathcal{J} = \left\| W_e(s) \frac{F(s)}{P_m(s) + F(s)} \right\|_\infty \quad (9)$$

Design method of the PFF can be regarded as a minimization problem of \mathcal{J} under the minimum-phase condition. This is one of the contributions of our paper. The evaluation function is minimized by using an optimization technique such as the particle swarm optimization(PSO)[12].

Next, case (ii) $n = 0, L \neq 0$ is considered. When the plant has a time-delay, $F(s)$ is taken to be the Smith predictor[9],[10],[13]. Thus, $F(s)$ is represented as

$$F(s) = P_0(s)(1 - e^{-Ls}). \quad (10)$$

Finally, case (iii) where $n \neq 0, L \neq 0$ is considered. $F(s)$ is created by combining the results (i) and (ii). First, the following $F_1(s)$ is defined to overcome the time-delay component:

$$F_1(s) = P_0(s) \prod_{i=1}^n \frac{s - z_i}{s + \bar{z}_i} (1 - e^{-Ls}) \quad (11)$$

Furthermore, to overcome undershoot, $F_2(s)$ is designed using Eq. (9) for virtual model $P_m^*(s) = P_m(s) + F_1(s) = P_0(s) \prod_{i=1}^n (s - z_i)/(s + \bar{z}_i)$. Then, $F(s)$ can be created by using sum of $F_1(s)$ and $F_2(s)$ as follows:

$$F(s) = F_1(s) + F_2(s) \quad (12)$$

Thus, the PFF $F(s)$ that overcomes the non-minimum-phase characteristics can be designed even when the plant has the characteristics $n \neq 0, L \neq 0$.

3.3.2 Design of $D(s)$

In this section, the design method for the compensator $D(s)$ based on [1] is shown. From the results of the previous section, each design condition C1 and C2 can be handled as an H_∞ control problem. Therefore, it is possible to consider the following design problem regarding $D(s)$ in Fig. 5.

[Problem 1] Find a $D(s)$ that minimizes the following evaluation function Γ_1 :

$$\Gamma_1 = \sup_{\Delta_P(s)} \left\| W_e(s) \frac{1}{1 + (P(s) + F(s))D(s)} \right\|_\infty \quad (13)$$

where $W_e(s)$ is a weighting function. The constraint condition is as follows:

- $D(s)$ is a robust stabilization controller for the feedback system with loop transfer function $(P(s) + F(s))D(s)$.

In Problem 1, the model error between the transfer function from u_c to y_f and $P_m(s) + F(s)$ is evaluated. Here, each condition in Problem 1 is given as the H_∞ norm. When $P_m(s) + F(s)$ is considered as the nominal model, it is a minimum-phase system owing to the designed $F(s)$ in 3.3.1. Furthermore, the design problem is equivalent to that in [1], because the model error $\Delta_P(s)$ is given an additive error. Problem 1 is the standard μ synthesis problem and can be solved numerically by MATLAB μ synthesis tool box.

Therefore, it is possible to obtain the numerical solution of $D(s)$ by using the numerical calculation software such as MATLAB to solve the H_∞ control problem. Moreover, it is expected that a smaller Γ_1 will be obtained because $P_m(s) + F(s)$ is the minimum-phase plant. This leads to suppression of the model error.

In previous research[1], when a nominal model $P_m(s)$ has a time delay, the structure of the MEC in Fig. 4 could not design a compensator $D(s)$ based on an H_∞ control problem. In contrast, using the proposed structure, a compensator $D(s)$ can be designed in the case of the nominal model $P_m(s)$ with the time delay, because the dead time is ignored by the PFF $F(s)$.

3.4 Elimination of constant disturbances and steady-state errors

In this section, an elimination method of a constant disturbance and a steady state error is discussed through limiting the structures of $D(s)$ and $F(s)$. When $F(s) = 0$, the proposed structure in Fig. 5 is equivalent to the traditional one in Fig. 4: the mentioned problems are eliminated by the $D(s)$ with the integrator shown in [1].

Here, it is assumed that the structures $D(s)$ and $F(s)$ are given as follows.

$$D(s) = \frac{1}{s}D_0(s), \quad F(s) = sF_0(s) \quad (14)$$

where, $D(s)$ and $F(s)$ have a pole at $s = 0$ and zero at $s = 0$, respectively. For example, $F(s)$ in Eq. (10) satisfies the condition shown in Eq. (14).

First, we consider the elimination of steady-state errors when a step input $\hat{u}(s) = 1/s$ is applied. An error signal is derived as follows:

$$\hat{e}(s) = \gamma(s)\Delta_P(s)\hat{u}(s) \quad (15)$$

$\hat{e}(s)$ becomes zero at a steady state regardless of $\Delta_P(s)$, provided that $\gamma(s)$ has zero at $s = 0$. By substituting Eq. (14) in Eq. (13), we obtain the following equation:

$$\gamma(s) = \frac{s(1 + F_0(s)D_0(s))}{s + (P(s) + sF_0(s))D_0(s)}. \quad (16)$$

From Eq. (16), $\gamma(s)$ has zero at $s = 0$ as long as $P(s)$ does not have zero at $s = 0$. Thus, it is confirmed that the steady-state error of $\hat{e}(s)$ becomes zero.

Next, the case where a step disturbance d is applied to the input u in Fig.5 is considered. The transfer function T_{yd} from d to y is represented as

$$T_{yd} = \frac{sP(s)(1 + F_0(s)D_0(s))}{s + (P(s) + sF_0(s))D_0(s)}. \quad (17)$$

From Eq. (17), if $1 + F_0(0)D_0(0)$ is not equal to zero, T_{yd} has zero at $s = 0$. Therefore, it can be seen that the influence of a step disturbance d is removed.

From the above results, when $D(s)$ and $F(s)$ have an integrator and zero at $s = 0$ respectively, steady-state error can be eliminated. Furthermore, if $F(s)$ is designed based on a Smith predictor in Eq. (10), then it is possible to remove a steady-state error automatically because the designed $F(s)$ necessarily has zero at $s = 0$.

4. Numerical examples

To show the effectiveness of the proposed method, a non-minimum-phase plant is considered. The transfer function of the plant is described as follows.

$$P(s) = \left(\frac{-(s-3)}{(s+1)(s+2)} + \frac{0.1}{(s+1)}\Delta(s) \right) e^{-0.5s} \quad (18)$$

$$\|\Delta\|_\infty < 1$$

$\Delta_P(s)$ in the simulation are shown in Fig.6.

The nominal model is

$$P_m(s) = \frac{-(s-3)}{(s+1)(s+2)} e^{-0.5s}. \quad (19)$$

First, the PFF $F(s)$ is designed. From Eq. (11) and Eq. (19), the filter $F_1(s)$ is designed as follows.

$$F_1(s) = \frac{-(s-3)}{(s+1)(s+2)} (1 - e^{-0.5s}) \quad (20)$$

The filter $F_2(s)$ is designed by minimizing Eq. (9). PSO algorithm is used to minimize Eq. (9) under the condition that $P_m + F$ is a stable minimum-phase system. Detailed design sequence is presented in Section A. As a result of PSO algorithm, the following filter $F_2(s)$ is obtained.

$$F_2(s) = \frac{11.4s^2 + 0.518s}{11.4s^3 + 34.9s^2 + 24.2s + 1} \quad (21)$$

Here, to confirm the effectiveness of $F(s)$, the step responses of $P_m(s)$, $F(s)$ and $P_m(s) + F(s)$ are shown in Fig.7. In this figure, dashed, dotted, and solid lines show the step responses of $P_m(s)$, $F(s)$ and $P_m(s) + F(s)$ respectively. $F(s)$ compensates any undershoot and time delay of $P_m(s)$. Therefore, the input-output relation of $P_m(s) + F(s)$ is regarded as a minimum-phase system.

Fig.8 shows the Bode diagrams of P_m and $P_m(s) + F(s)$. Gain diagram of $F(s)$ is also shown in Fig.8. We can find that phase delay of $P_m(s) + F(s)$ is smaller than that of $P_m(s)$, obviously.

Next, the compensator $D(s)$ is designed based on the design method of [1]. When this method is used, it is necessary to set the weighting function $W_e(s)$. To suppress the model error, especially in the steady state, the function $W_e(s)$ is set as follows:

$$W_e(s) = \frac{100}{(10s+1)^2} \quad (22)$$

As a result, the following compensator $D(s)$ is obtained.

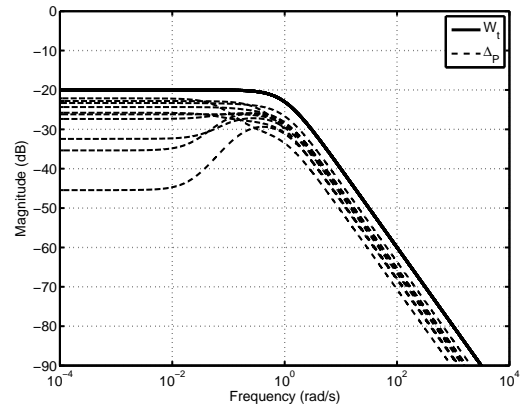

Fig. 6 Gain diagram of $\Delta_P(s)$

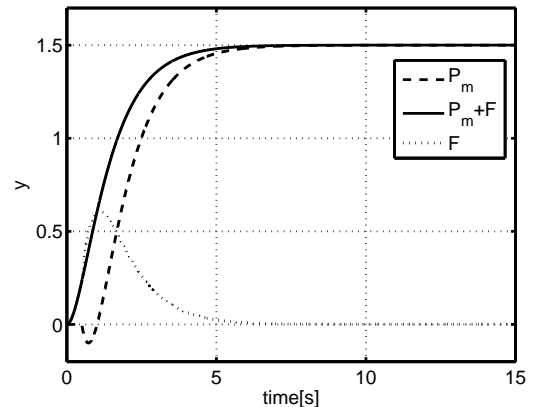

Fig. 7 Effect of PFF for $P_m(s)$

$$D(s) = \frac{D_{num}(s)}{D_{den}(s)} \quad (23)$$

$$D_{num}(s) = 1.41 \times 10^4 s^7 + 1.22 \times 10^5 s^6 + 4.35 \times 10^5 s^5 + 8.12 \times 10^5 s^4 + 8.40 \times 10^5 s^3 + 4.63 \times 10^5 s^2 + 1.11 \times 10^5 s + 4.08 \times 10^3$$

$$D_{den}(s) = s^8 + 1.98 \times 10^2 s^7 + 1.07 \times 10^4 s^6 + 4.31 \times 10^4 s^5 + 5.94 \times 10^4 s^4 + 3.18 \times 10^4 s^3 + 5.36 \times 10^3 s^2 + 3.30 \times 10^2 s + 6.65$$

From Fig. 9, the high gain compensator $D(s)$ can be designed in the low-frequency domain, which is influenced substantially by the model error. The above design results have been verified by the simulations. The effectiveness of the proposed method is confirmed here by inputting step and sine waves.

[Case A] Performance for a step input

First, step responses of $P(s)$ without a controller are shown in Fig.10. Solid black and dashed red lines denote the responses of $P(s)$ and $P_m(s)$, respectively. It can be seen that the responses of $P(s)$ are changed by the influence of the model error.

Next, step responses of the compensated system $P_c(s)$ using the proposed control system are shown in Fig. 11. Solid black and dashed red lines denote the responses of $P_c(s)$ and $P_m(s)$, respectively. In comparison with Fig.10, it is clear that the influence of the model error can be suppressed, especially in the steady state.

Here, to verify whether the designed compensator $D(s)$ suppresses the model error between the transfer function $P_{cf}(s)$

from u_c to y_f and $P_m(s) + F(s)$ in Fig.5, step responses of $P_{cf}(s)$ are shown in Fig.12. Solid black and dashed red lines represent the outputs of $P_{cf}(s)$ and $P_m(s) + F(s)$, respectively. From Fig. 12, the designed compensator $D(s)$ suppresses the model error between $P_{cf}(s)$ and $P_m(s) + F(s)$. This shows that the designed compensator $D(s)$ satisfies the design conditions in *Problem 1*.

From this result, we can confirm the effectiveness of the proposed control system.

[Case B] Performance for a sine wave

Output responses, that a sine wave ($\sin \pi t/7$) is used as input for $P(s)$, are shown in Fig.10. Solid black and dashed red lines show the responses of $P(s)$ and $P_m(s)$, respectively. The responses y are different from the output of the nominal model y_n because of the model error. The responses of the compensated system $P_c(s)$ are shown in Fig. 14. Solid black and dashed red lines are responses of $P_c(s)$ and $P_m(s)$, respectively. Comparing Fig. 14 with Fig. 13, confirms that variation from the output of the nominal model y_n is suppressed.

In the same manner as in *Case A*, in order to confirm that the designed compensator $D(s)$ satisfies the design conditions in *Problem 1*, step responses of $P_{cf}(s)$ are shown in Fig.15. Solid black and dashed red lines show outputs of $P_{cf}(s)$ and $P_m(s) + F(s)$, respectively. Fig.15 shows that the designed compensator $D(s)$ suppresses the model error between $P_{cf}(s)$ and $P_m(s) + F(s)$.

Therefore, the proposed control system is effective for a variety of the input signals.

5. Design of proposed compensator for MIMO plants

The proposed system is applied to MIMO systems in this section. The block diagram of the compensated system $P_{CF}(s)$ is shown in Fig. 16, for the case where the plant has n inputs and n outputs.

The PFF $F(s)$ can be designed using the design method shown in section 3.3.1. The designed $F(s)$ must satisfy the condition that each of the input and output characteristics of $P_M(s) + F(s)$ becomes a minimum-phase characteristics.

The design method of $D(s)$ is considered. In *Problem 1*, the designed $D(s)$ suppresses the model error between the transfer function from u_c to y_f and $P_M(s) + F(s)$ in Fig.5. Here, in Fig.16, the difference between the transfer function $P_{CF}(s)$ from u_c to y_f and $P_M(s) + F(s)$ is given as follows, with the subscript s omitted:

$$\begin{aligned} P_{CF} - (P_M + F) &= (I + (P + F)D)^{-1}(P + F + PD(P_M + F) + FD(P_M + F)) \\ &\quad - (P_M + F) \\ &= (I + (P + F)D)^{-1} \Delta_P \\ &= \epsilon' \Delta_P \end{aligned} \quad (24)$$

where I is an $n \times n$ unit matrix. $\epsilon'(s)$ in Eq. (24) is the matrix representation of an element in Eq. (25). As a result, a $D(s)$ for MIMO systems can be designed because the design method of the MEC for MIMO systems has been shown in [5]. Therefore, the following design problem regarding $D(s)$ for MIMO systems in Fig.16 can be considered.

[*Problem 2*] Find a $D(s)$ that minimizes the following evaluation function Γ_2 :

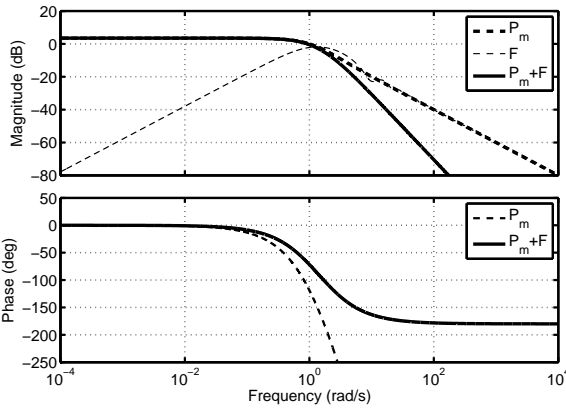

Fig. 8 Bode diagram of $P_m(s)$ and $P_m(s) + F(s)$

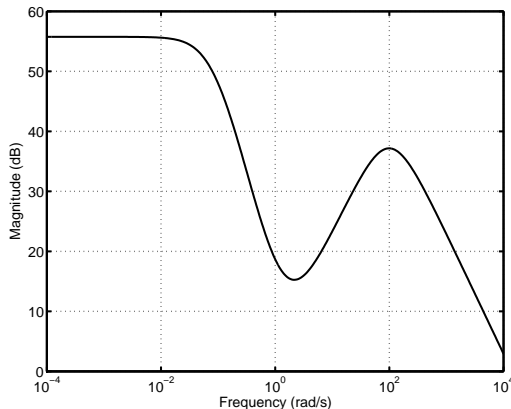

Fig. 9 Gain diagram of $D(s)$

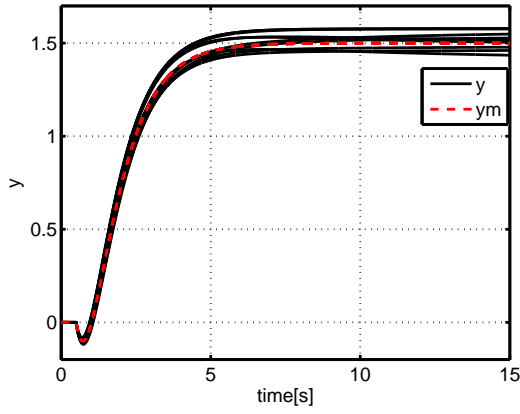

Fig. 10 Step responses of $P(s)$

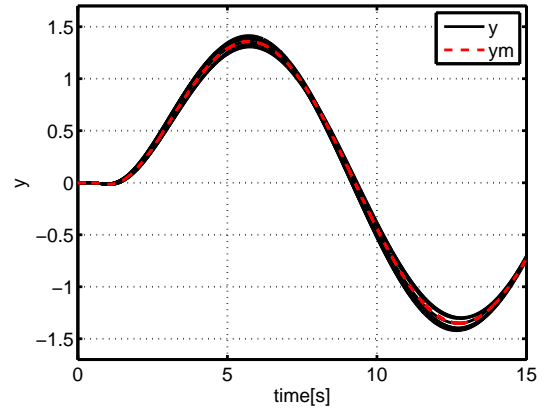

Fig. 13 Outputs of $P(s)$

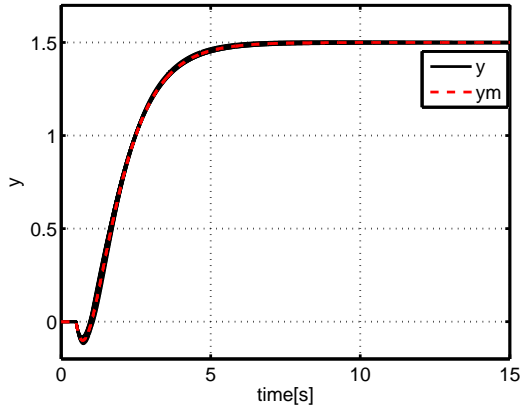

Fig. 11 Step responses of $P_c(s)$

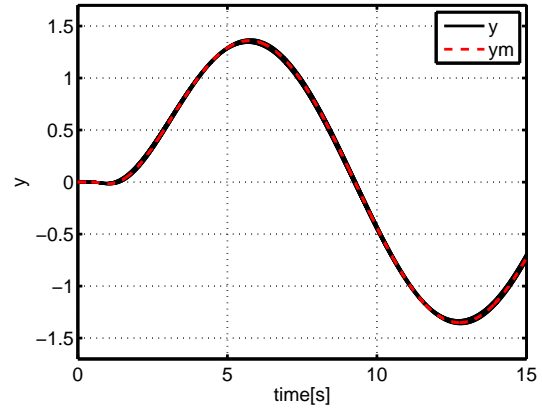

Fig. 14 Outputs of $P_c(s)$

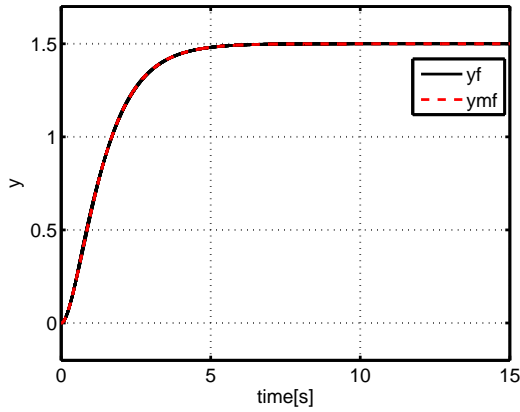

Fig. 12 Step responses of $P_{cf}(s)$

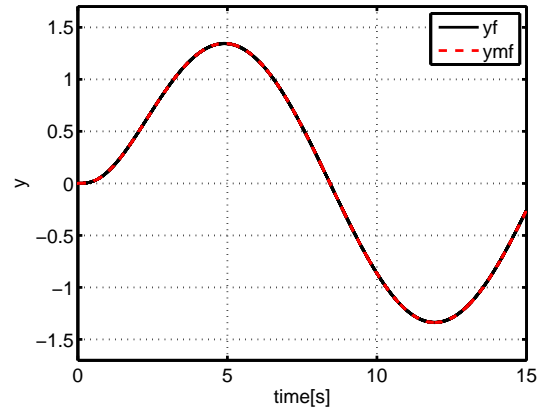

Fig. 15 Outputs of $P_{cf}(s)$

$$\Gamma_2 = \sup_{\Delta P(s)} \|W_e(s)(I + (P(s) + F(s))D(s))^{-1}\|_{\infty} \quad (25)$$

where $W_e(s)$ is a weighting function. The constraint condition is given as follows:

- $D(s)$ is the robust stabilization controller for the feedback system with loop transfer function $(P(s) + F(s))D(s)$.

As explained above, the PFF $F(s)$ and the compensator $D(s)$ can be designed even when the plant is a MIMO system.

6. Conclusion

This paper proposed an MEC with a PFF. A design method that uses the PFF to overcome a non-minimum-phase characteristics was shown. Moreover, a design method for the com-

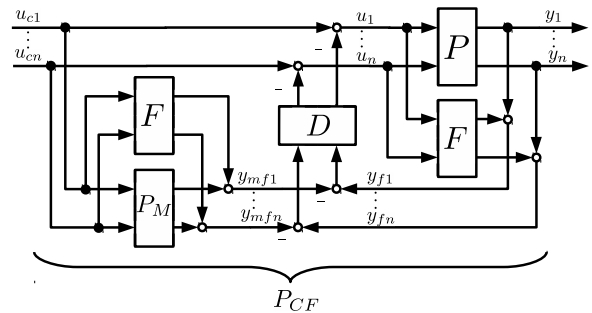

Fig. 16 MEC with PFF for MIMO system

pensator using the PFF was described. Simulations confirmed that the compensator with high model error suppression perfor-

mance can be designed. The effectiveness of the MEC with the PFF was illustrated through numerical simulations.

This work was supported by jsps kakenhi Grant-in-Aid for Scientific Research (C) 16K06419.

References

- [1] H. Okajima, H. Umei, N. Matsunaga and T. Asai : A Design Method of Compensator to Minimize Model Error , *SICE Journal of Control, Measurement, and System Integration* , Vol.6, No.4, pp.267-275, 2013.
- [2] A. T. Zengin, Y. Maruno, H. Okajima and N. Matsunaga : Maneuverability Improvement of Front-Drive-Type Electric Wheelchair STAVi , *SICE Journal of Control, Measurement, and System Integration* , Vol. 6, No. 6, pp. 419-442, 2013.
- [3] T. Fujioka, H. Okajima and N. Matsunaga : A Design Method of Robust Control System for Three-inertia Benchmark Problem Using Model Error Compensator and Frequency Shaped Final-state Control , *Transactions of the Society of Instrument and Control Engineers* , Vol.50 , No.12, pp.861-868, 2014(in Japanese).
- [4] H. Okajima, Y. Nishimura, N. Matsunaga and T. Asai : A Feedback Linearization Method for Non-linear Control Systems Based on Model Error Compensator , *Transactions of the Society of Instrument and Control Engineers* , Vol.50 , No.12, pp.869-874, 2014(in Japanese).
- [5] H. Umei, H. Okajima, N. Matsunaga and T. Asai : A Design Method of Model Error Compensator for MIMO Systems , *Transactions of the Institute of Systems, Control and Information Engineers* , Vol.27 , No.2, pp.67-72, 2014(in Japanese).
- [6] I. Bar-Kana: Parallel Feedforward and Simplified Adaptive Control , *International Journal of Adaptive Control and Signal Processing*, **1**, pp.95-109, 1987.
- [7] I. Mizumoto, T. Takagi and K. Yamanaka : Parallel Feedforward Compensator Design and ASPR based Adaptive Output Feedback Control for a Time-delay System , Proc. of 2013 American Control Conference, pp.4916-4921, 2013.
- [8] I. Mizumoto and Z. Iwai: Simplified Adaptive Model Output Following Control for Plants with Unmodelled Dynamics , *International Journal of Control* , Vol. 64, No. 1, pp.61-80, 1996.
- [9] S. Shah, Z. Iwai, I. Mizumoto, and M. Deng: Simple adaptive control of processes with time-delay, *Journal of Process Control*, Vol. 7, no. 6, pp. 439-449, 1997.
- [10] R. Gessing, Parallel Compensator versus Smith Predictor for Control of the Plants with Delay, *Bulletin of the Academy of Sciences Technical Sciences*, Vol. 56, No. 4, 2008
- [11] H. Kim, S. Kim, J. Back, H. Shim, J. H. Seo, Design of stable parallel feedforward compensator and its application to synchronization problem, *Automatica*, Vol. 64, pp. 208-216, 2016.
- [12] M. Clerc and J.Kennedy : The particle swarm - explosion, stability, and convergence in a multidimensional complex space, *IEEE Transactions on Evolutionary Computation*, Vol.6 , No.1 , pp.58-73, 2002.
- [13] O.J.M.Smith: A Controller to Overcome Dead Time, *ISAJ*, pp.28-33, 1959.
- [14] K. Zhou, J.C. Doyle, and K. Glover : *Robust and Optimal Control* , Prentice Hall, 1996.
- [15] M. Morari and E. Zafriou: *Robust Process Control*, Prentice Hall, 1989.
- [16] Karl J.Astrom : *Advanced PID Control, Instrumentation Systems*, 2005.

Gou ICHIMASA



He received his B.E. and M.E. from Kumamoto University, Japan, in 2014 and 2016, respectively. He joined Toshiba (Corp) in 2016. His research interests include control systems design.

Hiroshi OKAJIMA (Member)

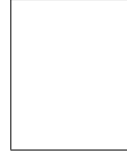

He received his M.E. and Ph.D degrees from Osaka University, Japan, in 2004 and 2007, respectively. He is presently associate professor of Kumamoto University, Japan. His research interests include tracking control, analysis of non-minimum-phase systems and data quantization for networked systems. He is a member of ISCIE and IEEE.

Kosuke OKUMURA (Student Member)

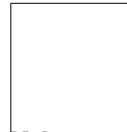

He received his B.E. from Kumamoto University, Japan, in 2015. He is currently a master's student at Kumamoto University. His research interests include control systems design.

Nobutomo MATSUNAGA (Member)

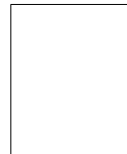

He received M.D. and Ph.D. degrees from Kumamoto University, Japan, in 1987 and 1993, respectively. He joined OMRON(Corp.) in 1987. Since 2002, he has been with the Department of Computer Science and Electrical Engineering, Kumamoto University, where he is a Professor. His research interests include thermal process control, automotive control, and human-machine system design. He is a member of IEEEJ and IEEE.

Appendix A PSO algorithm

In this section, a concrete design procedure to design $F_2(s)$, which minimize Eq. (9), is presented. The filter $F_2(s)$ is designed using PSO algorithm. Form of $F_2(s)$ is given as follow:

$$F_2(s) = \frac{a_1 s^2 + a_2 s}{a_3 s^3 + a_4 s^2 + a_5 s + 1}. \quad (\text{A. 1})$$

The parameter position is denoted as $p = [a_1, a_2, a_3, a_4, a_5]^T$. The parameter velocity is denoted as $\Delta p = [\Delta a_1, \Delta a_2, \Delta a_3, \Delta a_4, \Delta a_5]^T$.

The optimal parameter vector p is required to obtain from an optimization algorithm. Particle swarm optimization (PSO) is a computation method for optimizing a problem by iteratively trying to improve a solution. Multiple particles p_1, \dots, p_m are used in the PSO algorithm where m denotes the number of particles. $m = 100$ is used in this paper.

To minimize \mathcal{J} in Eq. (9), the following objective function $E(p)$ is determined.

$$E(p) = \begin{cases} \mathcal{J}(p) & \text{Minimum phase condition satisfied} \\ E_{pen} & \text{otherwise} \end{cases}$$

Penalty term is used if stable minimum-phase condition is not satisfied. The penalty E_{pen} is the larger positive value compared to a value of $\mathcal{J}(p)$ which is an acceptable solution. $E(p)$ becomes large value if the minimum phase condition of $P_m + F$ is not satisfied.

The position and the velocity of i -th particle are denoted as p_i and Δp_i , respectively. p_i is updated based on the following update laws.

$$p_i^{t+1} = p_i^t + \Delta p_i^{t+1} \quad (\text{A.2})$$

$$\begin{aligned} \Delta p_i^{t+1} = & \omega_0 \Delta p_i^t + \omega_1 \text{rand}_{1,i}^t (p_{pbest,i}^t - p_i^t) \\ & + \omega_2 \text{rand}_{2,i}^t (p_{gbest}^t - p_i^t) \end{aligned} \quad (\text{A.3})$$

t denote the iteration number and its initial value is $t = 0$. The maximum iteration number t_{\max} is given as 200 in this paper. ω_0 , ω_1 and ω_2 are the weighting coefficients which are given as positive values. The random numbers $\text{rand}_{1,i}^t$ and $\text{rand}_{2,i}^t$ are selected in the range $[0, 1]$. In (A.3), $p_{pbest,i}^t$ means the personal best solution which is determined as follow:

$$p_{pbest,i}^t := \arg \min_{x \in \{p_i^j | j=1,2,\dots,t\}} E(p). \quad (\text{A.4})$$

p_{gbest}^t means the global best solution which is determined as follow:

$$p_{gbest}^t := \arg \min_{x \in \{p_{pbest,i}^j | i=1,2,\dots,n\}} E(p). \quad (\text{A.5})$$

Then, PSO algorithm is given as following steps:

PSO algorithm

- **Step 1:** Set $t = 0$. For $i = 1, \dots, m$, initial position p_i^0 and velocity Δp_i^0 are selected randomly and evaluate the corresponding objective function E at each position.
- **Step 2:** Update $p_{pbest,i}^t$ and p_{gbest}^t by (A.4) and (A.5), respectively. Then, apply update laws (A.2) and (A.3) for all particles, and go to Step 3.
- **Step 3:** Evaluate all position p_i^t by (A.2). Set $t = t + 1$ and go to Step 2 if $t < t_{\max}$. Else, update $p_{pbest,i}^{t_{\max}}$ and $p_{gbest}^{t_{\max}}$.

By using PSO algorithm, Eq. (21) is obtained.